

62.0 36.0

40.00

222.0

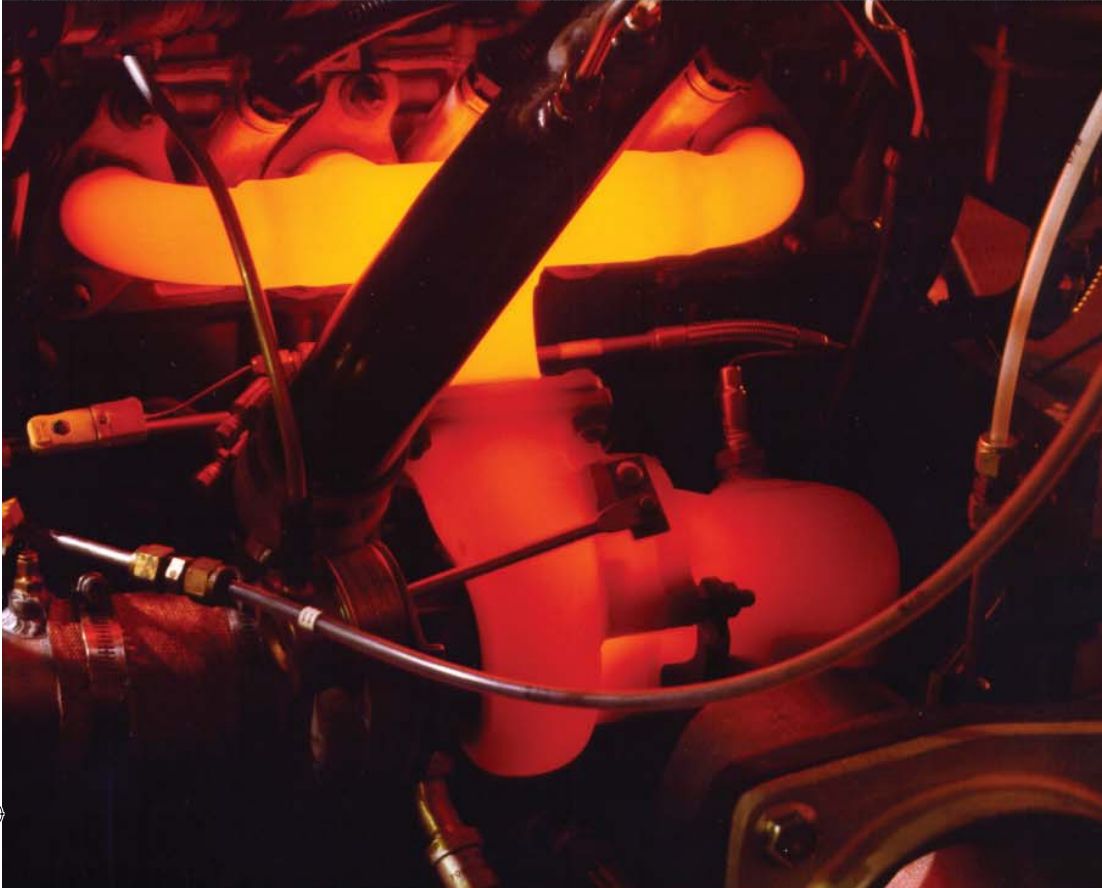

Garrett® TURBOCHARGERS

2008

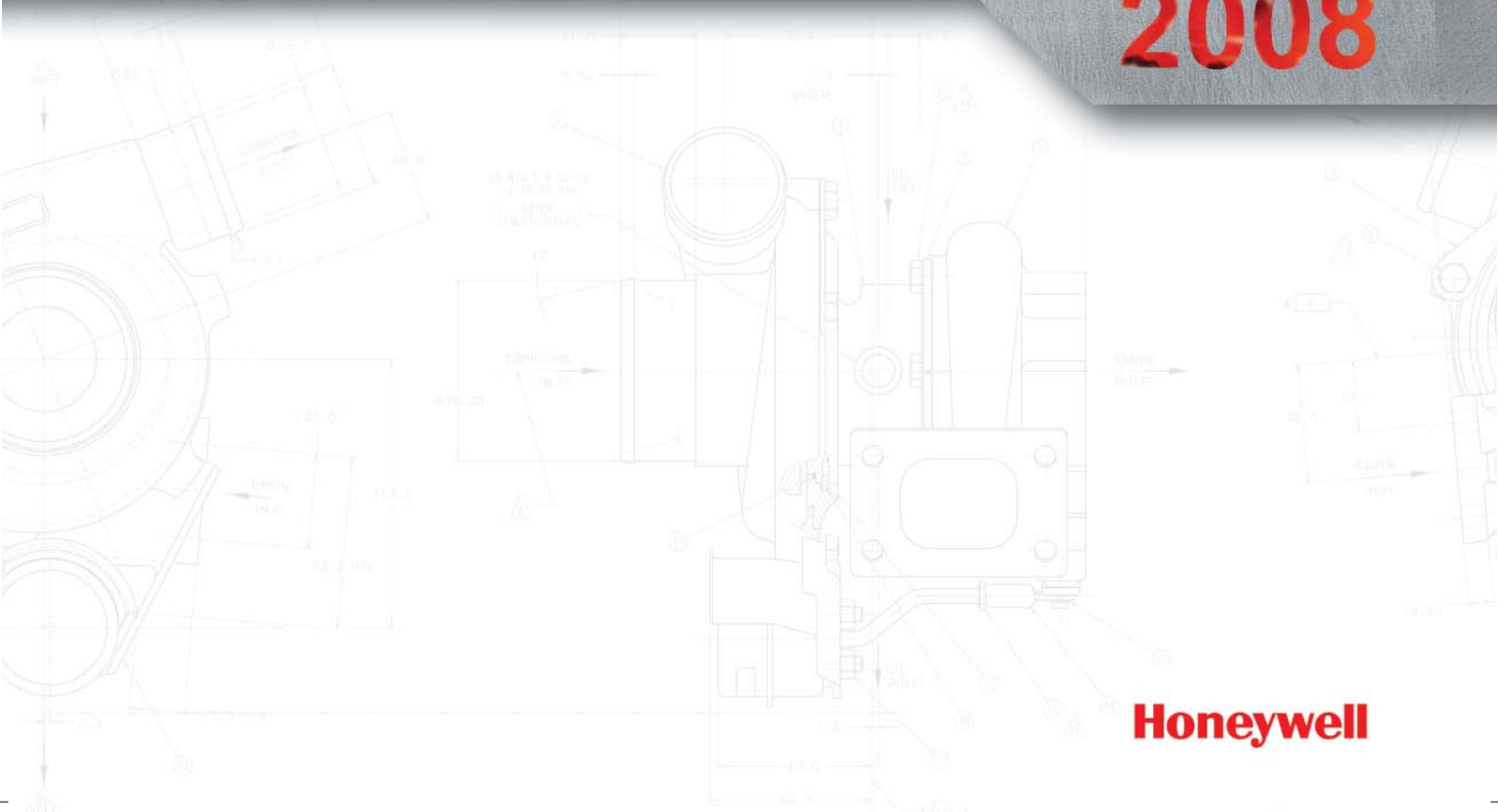

Honeywell

Champions Use Garrett

Garrett-Sponsored

Drag, Drift, Endurance, Land Speed, Oval
Road Course, Time Attack, Rally, Show

Garrett®



Ron Lummus Pontiac Sunfire GT4508R



Audi R10 TDI - Twin TR30R



Ed Bergholtz MazdaSpeed 6 GT4718R



Kyle Carter - Ecotec Dragster - Twin GT4294R



Champ Car Series GT4291



Guy Cosmo Mazda ALMS LMP2 TR30R



Art Dick - Freightliner - Four GT6041



Tanner Foust Nissan 350Z Twin GT2560R



Marcus Grönholm Ford Focus TR30R



Bryan Jimenez Chevy Cobalt GT4508R



Marty Ladwig Chevy Cobalt GT4708R



Gary Lang Nissan Silvia GT2871R



Sébastien Loeb Citroen Xsara TR30R



David Lott Ford F350 GT45R



Mark Mazurowski Nissan 240SX GT4294R



Tyler McQuarrie Nissan Silvia GT3076R



Dan Millen - Ford Mustang GT - GT6041



Stephan Papadakis Honda S2000 GT2871R



George & Rocky Rehayem Mazda MX6 GT5533



Ben Reyes Nissan Silvia GT2871R



Jonathan Reynolds Acura Integra GT4294R



John Romero Honda Civic GT3782



Tracy Shayhorn Nissan 240SX GT2871R



Carl Stevens Jr. - Nissan 350Z - Twin GT4718R



Paul Tolson - Lexus GS400 - Twin GT3582R



Kenny Tran Scion TC GT4202R



Stephan Verdier - Subaru WRX STI - GT3076R



Dr. Russ Warr - Subaru WRX STI - GT3582R



Dan Willie - Nissan 240SX - GT2871R



Kenji Yamanaka Nissan Silvia GT3076R

FOR #8, ITEM 11, 13, 14, 15, 20 WILL BE BAGGED TOGETHER AND PLACED IN THE BOX WITH THE TURBO.

12. CLEANLINESS PER OCT 9310-122.

Why Garrett®? / Turbo Testing Information.....pg 4

Turbo Basics; Turbo Choice, Trim & A/R.....pg 5

Turbo Tech; How a Turbo Workspg 6

Turbo Tech; How to Choose the Right Turbo - Gasolinepg 8

Turbo Tech; How to Choose the Right Turbo - Diesel.....pg 12

Turbo Tech; Troubleshooting & Servicepg 15

Displacement Chartspg 16

Garrett® GT Turbochargerspg 17

T-Series Ball Bearing Upgradespg 42

Diesel PowerMax™ Upgrade Kits.....pg 43

Turbocharger Connection Sizes & Dimensionspg 47

Wastegates & Blow-Off Valves.....pg 52

Intercoolers.....pg 53

Garrett® GT Turbocharger Indexpg 54

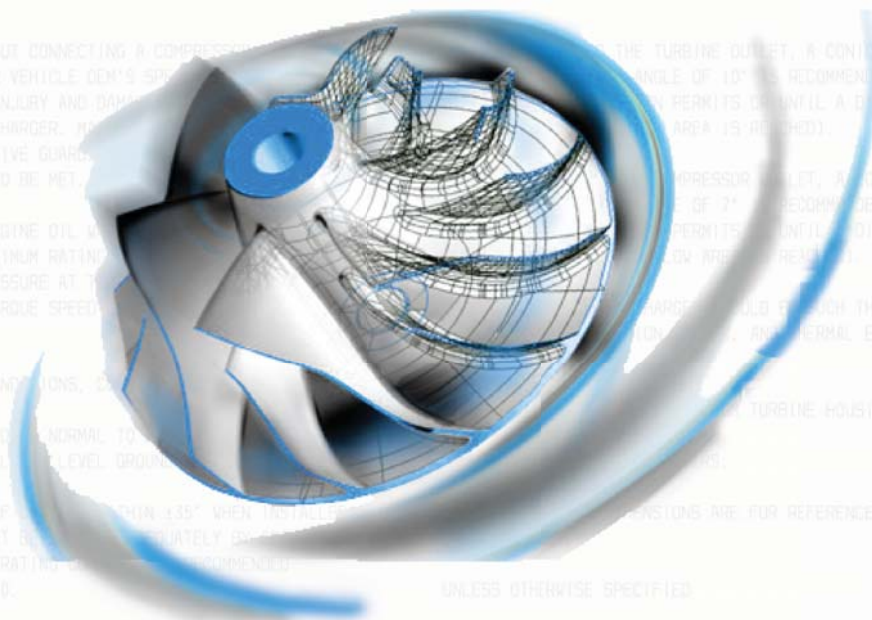

Why Garrett?

Garrett Dual Ball Bearing
GT Wheel Design

Garrett®

Why Garrett®?

A turbocharger is a highly technical product that requires superior design and intensive capital to produce. It must meet the most severe requirements that only a world-class manufacturer like Honeywell's Garrett® brand can achieve.

Garrett® is one of the few brands that subjects its turbos to several OE qualification tests that ensure that "Garrett" is only stamped on safe and reliable turbos! Some of these tests include:

* **On-Engine Durability** - A 1,000-hour general turbocharger durability test that is run on-engine in an engineering laboratory.

* **Compressor & Turbine Housing Containment** - A compressor/turbine wheel is weakened to "hub" burst at a specific speed. No portion of the wheel is allowed to penetrate a "containment shroud" surrounding the turbocharger; a test to ensure safety.

* **Shaft Motion** - The maximum tolerances of the bearing system are tested for rotordynamic stability beyond the maximum turbocharger operating speed. This means no bearing problems and a long turbo life.

* **Heat Soakback** - A turbocharger instrumented with thermocouples is taken beyond maximum operating temperature and shut down hard! Repeat this test four more times

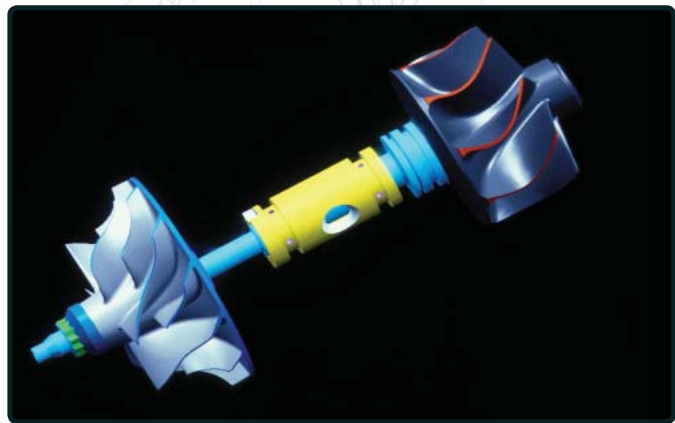

and make sure maximum temperatures stay within strict limits to avoid oil "coking" or build up inside the center housing. This is particularly critical for high temperature gasoline applications.

* **Thermal Cycle** - A 200-hour endurance test that cycles the turbocharger from low temperature to "glowing red" every 10 minutes. To ensure long turbo life, no cracking of the turbine housing or distortion of the heat shroud is accepted.

* **Rotor Inertia** - A measurement made to document the rotational inertia of the compressor and turbine wheels. Garrett® brand products are known for their high flow / low inertia characteristics.

Visit www.TurboByGarrett.com for complete test list.

Garrett Dual Ball Bearing

The Garrett® dual ball bearing cartridge gives better damping and control over shaft motion allowing enhanced reliability for both everyday and extreme driving conditions. The opposed angular contact bearing cartridge eliminates the need for the thrust bearing, commonly the weak link in the turbo bearing system. The bearing system in the GT

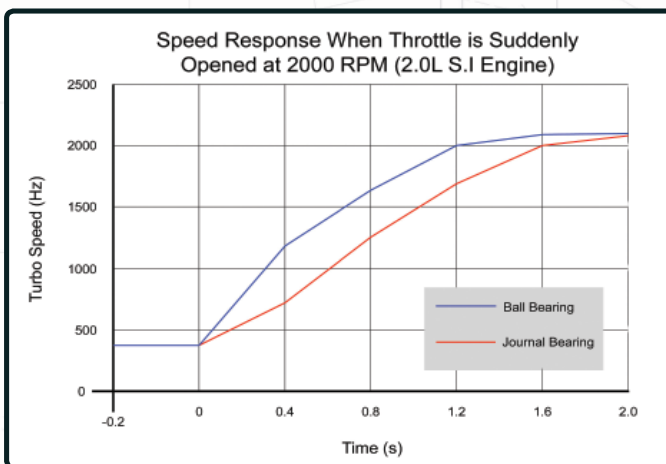

turbocharger allows for improved shaft stability and less drag throughout the speed range.

While T-series turbos typically contain 54 components, GT turbos have an average of only 29. The 45% decrease in parts diminishes the opportunity for failure and results in smoother operation.

GT Aerodynamics

New compressor and turbine blade designs have improved the overall efficiency of both sides of the turbocharger. The result is an engine that spools up to boost quicker with reduced losses in the system (i.e. your engine does not have to work as hard for the same boost level).

Today's team of over 850 engineers worldwide are working endless hours to further improve the reliability, durability and efficiency of the GT product line!

A Garrett® Turbo for Your Vehicle?

Garrett® is the only brand to offer a searchable database for turbo kits using its product.

Visit www.TurboByGarrett.com and enter your vehicle into our Turbo Application Search Engine (TASE) to find a turbo kit available for it using Garrett® turbochargers!

How Do I Choose the Right Turbo?

Selecting the proper turbocharger for your specific application requires many inputs. With decades of collective turbocharging experience, the Garrett® Performance Distributors can assist in selecting the right turbocharger for your application.

The primary input in determining which turbocharger is appropriate is to have a target horsepower in mind. This should be as realistic as possible for the application. Remember that engine power is generally proportional to air and fuel flow. Thus, once you have a target power level identified, you begin to hone in on the turbocharger size, which is highly dependent on air flow requirements.

Other important factors include the type of application. An autocross car, for example, requires rapid boost response. A smaller turbocharger or smaller turbine housing would be most suitable for this application. While this will sacrifice ultimate power due to increased exhaust backpressure at higher engine speeds, boost response of the small turbo will be excellent.

Alternatively, on a car dedicated to track days, peak horsepower is a higher priority than low-end torque. Plus, engine speeds tend to be consistently higher. Here, a larger turbocharger or turbine housing will provide reduced backpressure but less immediate low-end response. This is a welcome trade-off given the intended operating conditions.

Selecting the turbocharger for your application goes beyond “how much boost” you want to run. Defining your target power level and the primary use for the application are the first steps in selecting the best Garrett® Turbo for your vehicle. This catalog includes the formulas and considerations needed to correctly match a turbo to either your gasoline or diesel engine!

What is Trim?

Trim is an area ratio used to describe both turbine and compressor wheels. Trim is calculated using the inducer and exducer diameters.

Example:

Inducer diameter = 88mm

Exducer diameter = 117.5mm

Trim = (Inducer²/Exducer²) x 100

Trim = (88²/117.5²) x 100 = 56 Trim

As trim is increased, the wheel can support more air/gas flow.

What is A/R?

A/R describes a geometric characteristic of all compressor and turbine housings. It is defined as the inlet cross-sectional area divided by the radius from the turbo centerline to the centroid of that area.

Compressor A/R - Compressor performance is largely insensitive to changes in A/R, but generally larger A/R housings are used to optimize the performance for low boost applications, and smaller housings are used for high boost applications. Usually there are not A/R options available for compressor housings.

Turbine A/R - Turbine performance is greatly affected by changing the A/R of the housing. Turbine A/R is used to adjust the flow capacity of the turbine. Using a smaller A/R will increase the exhaust gas velocity into the turbine wheel, causing the wheel to spin faster at lower engine RPMs giving a quicker boost rise. This will also tend to increase exhaust backpressure and reduce the max power at high RPM. Conversely, using a larger A/R will lower exhaust gas velocity and delay boost rise, but the lower backpressure will give better high-RPM power. When deciding between A/R options, be realistic with the intended vehicle use and use the A/R to bias the performance toward the desired powerband.

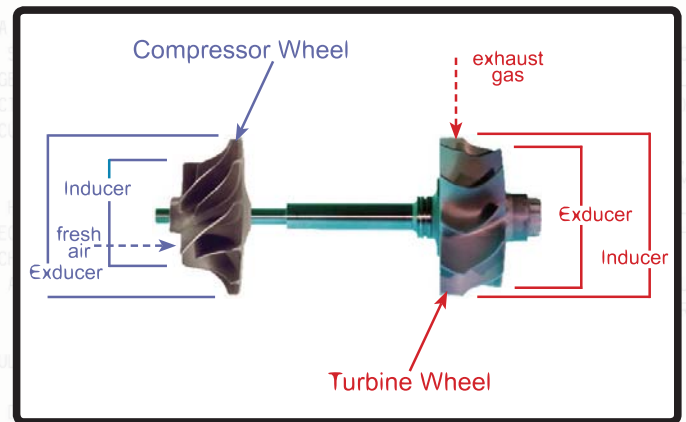
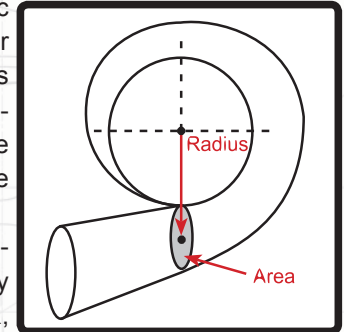

How a Turbo Works

All About Turbochargers, Wastegates & Blow-Off Valves

Garrett®

How a Turbo System Works

Engine power is proportional to the amount of air and fuel that can get into the cylinders. All else being equal, larger engines flow more air and as such will produce more power.

If we want our small engine to perform like a big engine, or simply make our bigger engine produce more power, our ultimate objective is to draw more air into the cylinder. By installing a Garrett® brand turbocharger, the power and performance of an engine can be dramatically increased.

The layout of the turbocharger in a given application is critical to a properly performing system.

So how does a turbocharger get more air into the engine? Let us first look at the schematic to the upper right.

- Ambient air passes through the air filter (not shown) before entering the compressor [1].
- The air is then compressed which raises the air's density (mass / unit volume) [2].
- Many turbocharged engines have a charge air cooler (aka intercooler) [3]

that cools the compressed air to further increase its density and to increase resistance to detonation.

- After passing through the intake manifold [4], the air enters the engine's cylinders, which contain a fixed volume. Since the air is at an elevated density, each cylinder can draw in an increased mass of air. Higher air mass flow rate allows a higher fuel flow rate (with similar air/fuel ratio). Combusting more fuel results in more power being produced for a given size or displacement.
- After the fuel is burned in the cylinder it is expelled during the cylinder's exhaust stroke into the exhaust manifold [5].
- The high temperature gas then continues on to the turbine [6]. The turbine creates backpressure on the engine which means engine exhaust

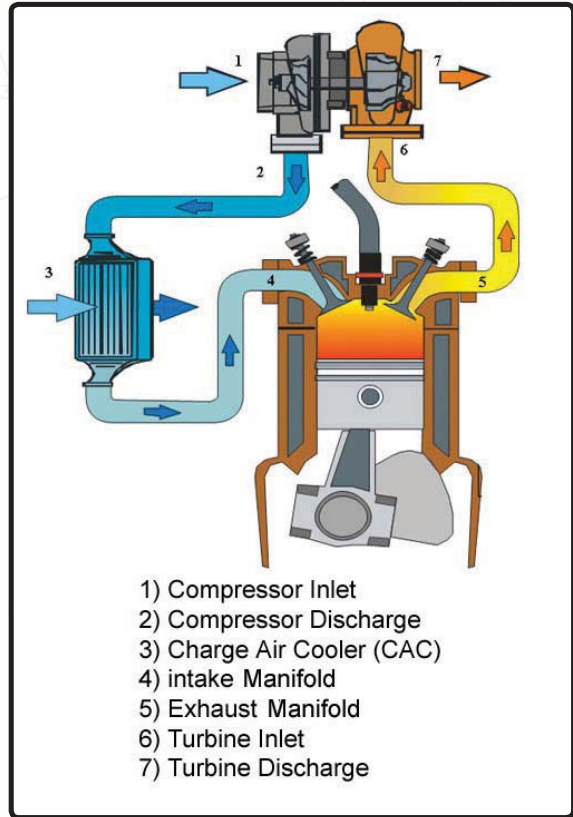

- 1) Compressor Inlet
- 2) Compressor Discharge
- 3) Charge Air Cooler (CAC)
- 4) intake Manifold
- 5) Exhaust Manifold
- 6) Turbine Inlet
- 7) Turbine Discharge

pressure is higher than atmospheric pressure.

- A pressure and temperature drop occurs (expansion) across the turbine [7], which harnesses the energy of the exhaust gas to provide the power necessary to drive the compressor.

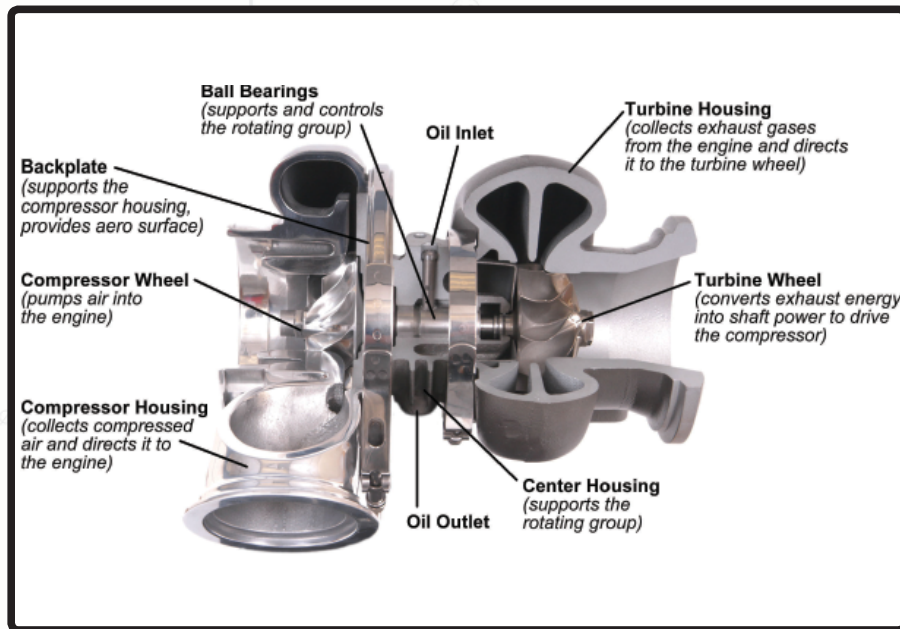

What are the Components of a Turbocharger?

- Compressor Housing
- Turbine Housing
- Center Housing and Rotating Assembly (CHRA)
 - Compressor Wheel
 - Turbine Wheel Assembly (wheel and shaft)
 - Backplate
 - Bearing System
 - Oil Inlet
 - Oil Outlet

How a Turbo Works

All About Turbochargers Wastegates & Blow-Off Valves

Other Components

Blow-Off (Bypass) Valves

The blow-off valve (BOV) is a pressure relief device on the intake tract to prevent the turbo's compressor from going into surge. The BOV should be installed between the compressor discharge and the throttle body, preferably downstream of the charge air cooler (if equipped).

When the throttle is closed rapidly, the airflow is quickly reduced, causing flow instability and pressure fluctuations. These rapidly cycling pressure fluctuations are the audible evidence of surge. Surge can eventually lead to thrust bearing failure due to the high loads associated with it.

Blow-off valves use a combination of manifold pressure signal and spring force to detect when the throttle is closed. When the throttle is closed rapidly, the BOV vents boost from the intake tract to atmosphere to relieve the pressure from the turbo, eliminating surge.



Wastegates

On the exhaust side, a wastegate provides a means to control the boost pressure of the engine. Some commercial diesel applications do not use a wastegate at all. This type of system is called a free floating turbocharger.

However, the vast majority of gasoline performance applications require a wastegate. There are two configurations of wastegates: internal and external. Both internal and external wastegates provide a means to bypass

exhaust flow from the turbine wheel. Bypassing this energy (e.g. exhaust flow) reduces the power driving the turbine wheel to match the power required for a given boost level. Similar to the BOV, the wastegate uses boost pressure and spring force to regulate the flow bypassing the turbine.

Internal wastegates are built into the turbine housing and consist of a "flapper" valve, crank arm, rod end, and pneumatic actuator. It is important to connect this actuator only to boost pressure since it is not designed to handle vacuum and as such should not be referenced to an intake manifold.



External wastegates are added to the exhaust plumbing on the exhaust manifold or header. The advantage of external wastegates is that the bypassed flow can be reintroduced into the exhaust stream further downstream of the turbine. This improves the turbine's performance. On racing applications, this wastegated exhaust flow can be vented directly to atmosphere.



Oil & Water Plumbing

The intake and exhaust plumbing often receives the focus, leaving the oil and water plumbing neglected.

Garrett® ball bearing turbochargers require less oil than journal bearing turbos. Therefore an oil inlet restrictor is recommended if you have oil pressure over approximately 40 psig. The oil outlet should be plumbed to the



oil pan above the oil level (for wet sump systems). Since the oil drain is gravity fed, it is important that the oil outlet points downward, and that the drain tube does not become horizontal or go "uphill" at any point.

Following a hot shutdown of a turbocharger, heat soak begins. This means that the heat in the head, exhaust manifold, and turbine housing raises the temperature of the turbo's center housing. These extreme temperatures can result in oil coking.

Water-cooled center housings were introduced to minimize the effects of heat soak-back. These use unpressurized coolant from the engine to act as a heat sink after engine shutdown, preventing the oil from coking. The water lines utilize a thermal siphon effect to reduce the peak heat soak-back temperature after key-off. The layout of the pipes should eliminate peaks and troughs with the (cool) water inlet on the low side. To help this along, it is advantageous to tilt the turbocharger approximately 25° about the axis of shaft rotation.

Garrett® offers many turbos that are water-cooled for enhanced durability.

Want to learn more?

Visit <http://www.TurboByGarrett.com> and check out the Turbo Tech section for more great articles!

Turbo Selection - Gas

The Correct Way to Choose a Turbo
Directly From the Garrett® Engineers

Garrett®

This article is more involved and will describe parts of the compressor map, how to estimate pressure ratio and mass flow rate for your engine as well as how to plot the points on the maps to help choose the right turbocharger. Have your calculator handy!

Parts of the Compressor Map

The compressor map is a graph that describes a particular compressor's performance characteristics, including efficiency, mass flow range, boost pressure capability, and turbo speed. Shown below is a figure that identifies aspects of a typical compressor map:

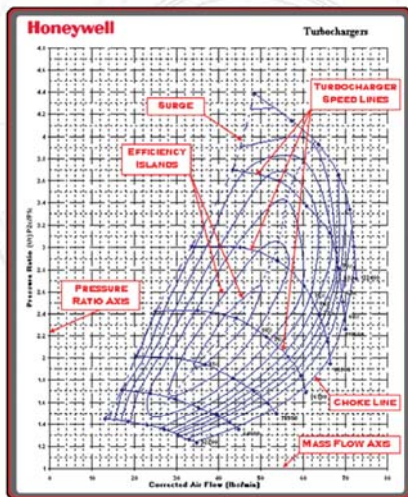

Pressure Ratio

Pressure Ratio (Π_c) is defined as the Absolute outlet pressure divided by the Absolute Inlet Pressure.

Where:

Π_c = Pressure Ratio
 P1c = Compressor Inlet Pressure
 P2c = Compressor Discharge Pressure

It is important to use units of Absolute Pressure for both P1c and P2c. Remember that Absolute Pressure at sea level is 14.7 psia (in units of psia, the "a"

refers to "absolute"). This is referred to as standard atmospheric pressure at standard conditions.

Gauge Pressure (in units of psig, the g refers to "gauge") measures the pressure above atmospheric, so a Gauge Pressure reading at atmospheric conditions will read zero. Boost gauges measure the manifold pressure relative to atmospheric pressure, and thus are measuring Gauge Pressure. This is important when determining P2c. For example, a reading of 12 psig on a boost gauge means that the air pressure in the manifold is 12 psi above atmospheric pressure. For a day at standard atmospheric conditions, 12 psig + 14.7 psia = 26.7 psi Absolute Pressure in the manifold, the Pressure Ratio at this condition can now be calculated:

$$26.7 \text{ psia} / 14.7 \text{ psia} = 1.82$$

However, this assumes there is no adverse impact of the air filter assembly at the compressor inlet.

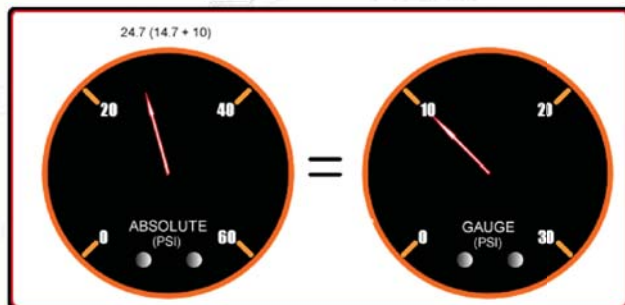

In determining Pressure Ratio, the Absolute Pressure at the compressor inlet (P1c) is often LESS than the Ambient Pressure, especially at high load. Why is this? Any restriction (caused by the air filter or restrictive ducting) will result in a "depression,"

or pressure loss, upstream of the compressor that needs to be accounted for when determining pressure ratio. This depression can be 1 psig or more on some intake systems. In this case P1c on a standard day is:

$$14.7 \text{ psia} - 1 \text{ psig} = 13.7 \text{ psia at compressor inlet}$$

Taking into account the 1 psig intake depression, the pressure ratio is now.

$$(12 \text{ psig} + 14.7 \text{ psia}) / 13.7 \text{ psia} = 1.95$$

That's great, but what if you're not at sea level? In this case, simply substitute the actual atmospheric pressure in place of the 14.7 psi in the equations above to give a more accurate calculation. At higher elevations, this can have a significant effect on pressure ratio.

For example, at Denver's 5000 feet elevation, the atmospheric pressure is typically around 12.4 psia. In this case, the pressure ratio calculation, taking into account the intake depression, is:

$$(12 \text{ psig} + 12.4 \text{ psia}) / (12.4 \text{ psia} - 1 \text{ psig}) = 2.14$$

Compared to the 1.82 pressure ratio calculated originally, this is a big difference.

As you can see in these examples, pressure ratio depends on a lot more than just boost.

Mass Flow Rate

Mass Flow Rate is the mass of air flowing through a compressor (and engine!) over a given period of time and is commonly expressed as lb/min (pounds per minute). Mass flow can be physically measured, but in many cases it is sufficient to estimate the mass flow for choosing the proper turbo.

Many people use Volumetric Flow Rate (expressed in cubic feet per minute, CFM or ft³/min) instead of mass flow rate. Volumetric flow rate can be converted to mass flow by multiplying by the air density. Air density at sea level is 0.076lb/ft³.

What is my mass flow rate? As a very general rule, turbocharged gasoline engines will generate 9.5-10.5 horsepower (as measured at the flywheel) for each lb/min of airflow. So, an engine with a target peak horsepower of 400 HP will require 36-44 lb/min of airflow to achieve that target. This is just a rough first approximation to help narrow the turbo selection options.

Surge Line

Surge is the left hand boundary of the compressor map. Operation to the left of this line represents a region of flow instability. This region is characterized by mild flutter to wildly fluctuating boost and "barking" from the compressor. Continued operation within this region can lead to premature turbo failure due to heavy thrust loading.

Surge is most commonly experienced when one of two situations exist. The first and most damaging is surge under load. It can be an indication that your compressor is too large. Surge is also commonly experienced when the throttle is quickly closed after boosting. This occurs because mass flow is drastically reduced as the throttle is closed, but the turbo is still spinning and generating boost. This immediately drives the operating point to the far left of the compressor map, right into surge. Surge will decay once the turbo speed finally slows enough to reduce the boost and move the operating point back into the stable region. This situation is commonly addressed by using a Blow-Off Valve (BOV) or bypass valve. A BOV functions to vent intake pressure to atmosphere so that the mass flow ramps down smoothly, keeping the compressor out of surge. In the case of a recirculating bypass valve, the airflow

is recirculated back to the compressor inlet.

A Ported Shroud Compressor (see Fig. 2) is a feature that is incorporated into the compressor housing. It functions to move the surge line further to the left (see Fig. 3) by allowing some airflow to exit the wheel through the port to keep surge from occurring. This provides additional useable range and allows a larger compressor to be used for higher flow requirements without risking running the compressor into a dangerous surge condition. The presence of the ported shroud usually has a minor negative impact on compressor efficiency.

The Choke Line is the right hand boundary of the compressor map. For Garrett® maps, the choke line is typically defined by the point where the efficiency drops below 58%. In addition to the rapid drop of compressor efficiency past this point, the turbo speed will also be approaching or exceeding the allowable limit. If your actual or predicted operation is beyond this limit, a larger compressor is necessary.

Turbo Speed Lines are lines of constant turbo speed. Turbo speed for points between these lines can be estimated by interpolation. As turbo speed increases, the pressure ratio increases and/or mass flow increases. As indicated above in the choke line description, the turbo speed lines are very close together at the far right edge of the map. Once a compressor is operating past the choke limit, turbo speed increases very quickly and a turbo over-speed condition is very likely.

Efficiency Islands are concentric regions on the maps that represent the compressor efficiency at any point on the map. The smallest island near the center of the map is the highest or peak efficiency island. As the rings move out from there, the efficiency drops by the indicated amount until the surge and choke limits are reached.

Plotting Your Data on the Compressor Map

In this section, methods to calculate mass flow rate and boost pressure required to meet a horsepower target are presented. This data will then be used to choose the appropriate compressor and turbocharger. Having a Horsepower Target in mind is a vital part of the process. In addition to being necessary for calculating mass flow and boost pressure, a Horsepower Target is required for choosing the right fuel injectors, fuel pump and regulator, and other engine components.

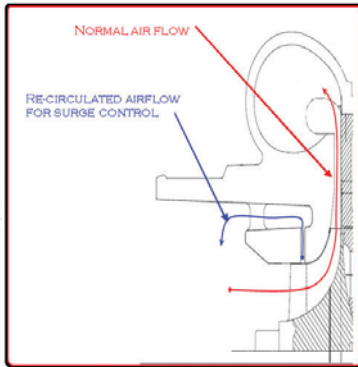

Fig 2

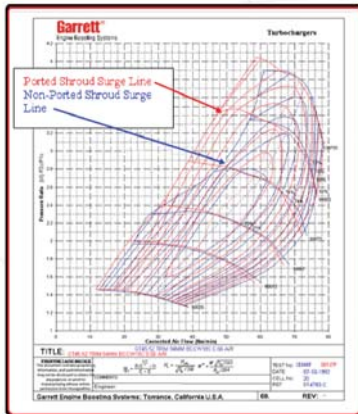

Fig 3

Estimating Required Air Mass Flow and Boost Pressures to reach a Horsepower Target.

Things you need to know:

- Horsepower Target
- Engine Displacement
- Maximum RPM
- Ambient conditions (temperature and barometric pressure. Barometric pressure is usually given as inches of mercury and can be converted to psi by dividing by 2)

Things you need to estimate:

- Engine Volumetric Efficiency. Typical numbers for peak Volumetric Efficiency (VE) range in the 95%-99% for modern 4-valve heads, to 88%-95% for 2-valve designs. If you have a torque curve for your engine, you can use this to estimate VE at various engine speeds. On a well-tuned engine, the VE will peak at the torque peak, and this number can be used to scale the VE at other engine speeds. A 4-valve engine will typically have higher VE over more of its rev range than a 2-valve engine.
- Intake Manifold Temperature. Compressors with higher efficiency give lower manifold temperatures. Manifold temperatures of intercooled setups are typically 100 - 130 degrees F, while non-intercooled values can reach from 175-300 degrees F.
- Brake Specific Fuel Consumption (BSFC). BSFC describes the fuel flow rate required to generate each horsepower. General values of BSFC for turbocharged gasoline engines range from 0.50 to 0.60 and higher.

The units of BSFC are $\frac{lb}{Hp*hr}$

Lower BSFC means that the engine requires less fuel to generate a given horsepower. Race fuels and aggressive tuning are required to reach the low end of the BSFC range described above.

For the equations below, we will divide BSFC by 60 to convert from hours to minutes.

To plot the compressor operating point, first calculate airflow:

Where: $Wa = \frac{HP * A/F * BSFC}{60}$ actual (lb/min)

Wa= Airflow

HP = Horsepower Target (flywheel)

A/F = Air/Fuel Ratio

BSFC/60 = Brake Specific Fuel Consumption = $(\frac{lb}{Hp*hr}) \div 60$ (to convert from hours to minutes)

EXAMPLE:

I have an engine that I would like to make 400HP, I want to choose an air/fuel ratio of 12 and use a BSFC of 0.55. Plugging these numbers into the formula from above:

$$Wa = 400 * 12 * \frac{0.55}{60} = 44.0 \frac{lb}{min} \text{ of air.}$$

Thus, a compressor map that has the capability of at least 44 pounds per minute of airflow capacity is a good starting point.

Note that nowhere in this calculation did we enter any engine displacement or RPM numbers. This means that for any engine, in order to make 400 HP, it needs to flow about 44 lb/min (this assumes that BSFC remains constant across all engine types). Naturally, a smaller displacement engine will require more boost or higher engine speed to meet this target than a larger engine will. So how much boost pressure would be required?

Calculate required manifold pressure required to meet the Horsepower, or flow target:

Turbo Selection - Gas

The Correct Way to Choose a Turbo
Directly From the Garrett® Engineers

Garrett®

Where:
$$MAP_{req} = \frac{Wa * R * (460 + T_m)}{VE * \frac{N}{2} * Vd}$$

- MAPreq = Manifold Absolute Pressure (psia) required to meet the horsepower target
- Wa = Airflow actual (lb/min)
- R = Gas Constant = 639.6
- Tm = Intake Manifold Temperature (degrees F)
- VE = Volumetric Efficiency
- N = Engine speed (RPM)
- Vd = engine displacement (Cubic Inches, convert from liters to CI by multiplying by 61.02, ex. 2.0 liters * 61.02 = 122 CI)

EXAMPLE:

To continue the example above, let's consider a 2.0 liter engine with the following description:

- Wa = 44 lb/min as previously calculated
- Tm = 130 degrees F
- VE = 92% at peak power
- N = 7200 RPM
- Vd = 2.0 liters * 61.02 = 122 CI

$$MAP_{req} = \frac{44 * 639.6 * (460 + 130)}{.92 * \frac{7200}{2} * 122} = 41.1 \text{ psia (remember, this is Absolute Pressure. Subtract Atmospheric Pressure to get Gauge Pressure (aka boost):}$$

41.1 psia - 14.7 psia (at sea level) = 26.4 psig boost

As a comparison let's repeat the calculation for a larger displacement 5.0L (4942 cc/302 CI) engine.

Where:

- Wa = 44 lb/min as previously calculated
- Tm = 130 degrees F
- VE = 85% at peak power (it is a pushrod V-8)
- N = 6000 RPM
- Vd = 4.942*61.02= 302 CI

$$MAP_{req} = \frac{44 * 639.6 * (460 + 130)}{.85 * \frac{6000}{2} * 302} = 21.6 \text{ psia (or 6.9 psig boost)}$$

This example illustrates that in order to reach the horsepower target of 400 hp, a larger engine requires lower manifold pressure but still needs 44lb/min of airflow. This can have a very significant effect on choosing the correct compressor.

With Mass Flow and Manifold Pressure, we are nearly ready to plot the data on the compressor map. The next step is to determine how much pressure loss exists between the compressor and the manifold. The best way to do this is to measure the pressure drop with a data acquisition system, but many times that is not practical.

Depending upon flow rate, charge air cooler characteristics, piping size, number/quality of the bends, throttle body restriction, etc., the plumbing pressure drop can be estimated. This can be 1 psi or less for a very well designed system. On certain restrictive OEM setups, especially those that have now higher-than-stock airflow levels, the pressure drop can be 4 psi or greater.

For our examples we will assume that there is a 2 psi loss. So to determine the Compressor Discharge Pressure (P2c), 2 psi will be added to the manifold pressure calculated above.

Where:

$$P_{2c} = MAP + \Delta P_{loss}$$

- P2c = Compressor Discharge Pressure (psia)
- MAP = Manifold Absolute Pressure (psia)
- ΔPloss = Pressure Loss Between the Compressor and the Manifold (psi)

For the 2.0 L engine: $P_{2c} = 41.1 + 2 = 43.1 \text{ psia}$

For the 5.0 L engine: $P_{2c} = 21.6 + 2 = 23.6 \text{ psia}$

Remember our discussion on inlet depression in the Pressure Ratio discussion earlier, we said that a typical value might be 1 psi, so that is what will be used in this calculation. For this example, assume that we are at sea level, so Ambient Pressure is 14.7 psia.

We will need to subtract the 1 psi pressure loss from the ambient pressure to determine the Compressor Inlet Pressure (P1c).

Where:

$$P_{1c} = P_{amb} - \Delta P_{loss}$$

- P1c = Compressor Inlet Pressure (psia)
 - Pamb = Ambient Air Pressure (psia)
 - ΔPloss = Pressure Loss due to Air Filter/Piping (psi)
- P1c = 14.7 - 1 = 13.7 psia

With this, we can calculate Pressure Ratio (Πc) using the equation.

$$\Pi_c = \frac{P_{2c}}{P_{1c}}$$

For the 2.0 L engine: $\Pi_c = \frac{43.1}{13.7} = 3.14$

For the 5.0 L engine: $\Pi_c = \frac{23.6}{13.7} = 1.72$

We now have enough information to plot these operating points on the compressor map. First we will try a GT2860RS. This turbo has a 60mm, 60 trim compressor wheel.

Clearly this compressor is too small, as both points are positioned far to the right and beyond the compressor's choke line.

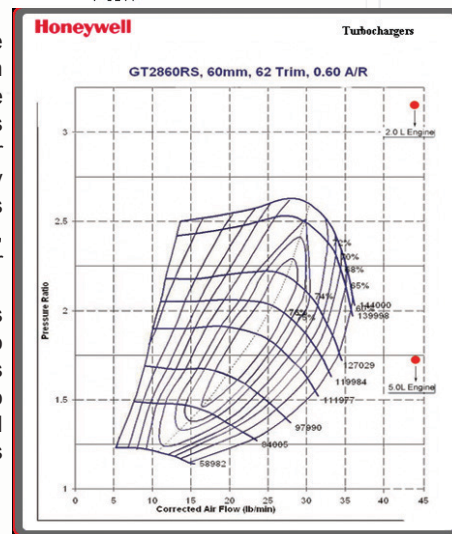

pursuit of power

Turbo Tech > Choosing your Turbo > Gasoline
Turbo Selection - Gas
 The Correct Way to Choose a Turbo
 Directly From the Garrett® Engineers

Another potential candidate might be the Garrett® GT3076R. This turbo has a 76mm, 56 trim compressor wheel.

This is much better; at least both points are on the map! Let's look at each point in more detail.

For the 2.0L engine this point is in a very efficient area of the map, but since it is in the center of the map, there would be a concern that at lower engine speeds that it would be near or over the surge line. This might be ok for a high-rpm-biased powerband that might be used on a racing application, but a street application would be better served by a different compressor.

For the 5.0L engine, this looks like a very good street-biased powerband, with the lower engine speeds passing through the highest efficiency zone on the map, and plenty of margin to stay clear of surge. One area of concern would be turbo overspeed when revving the engine past peak power. A larger compressor would place the operating point nearer to the center of the map and would give some additional benefit to a high-rpm-biased powerband. We'll look at a larger compressor for the 5.0L after we figure out a good street match for the 2.0L engine.

So now lets look at a Garrett® GT3071R, which uses a 71mm, 56 trim compressor wheel.

For the 2.0L engine, this is a better mid-range-oriented compressor. The operating point is shifted a bit towards the choke side of the map and this provides additional surge margin. The lower engine speeds will now pass through the higher efficiency zones and give excellent performance and response.

For the 5.0L engine, the compressor is clearly too small and would not be considered.

Now that we have arrived at an acceptable compressor for the 2.0L engine, lets calculate a lower rpm point to plot on the map to better get a feel for what the engine operating line will look like. We can calculate this using the following formula:

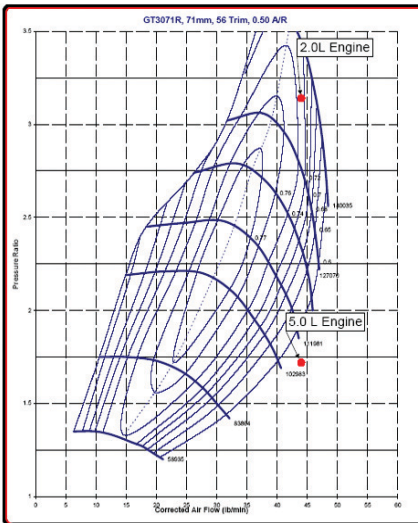
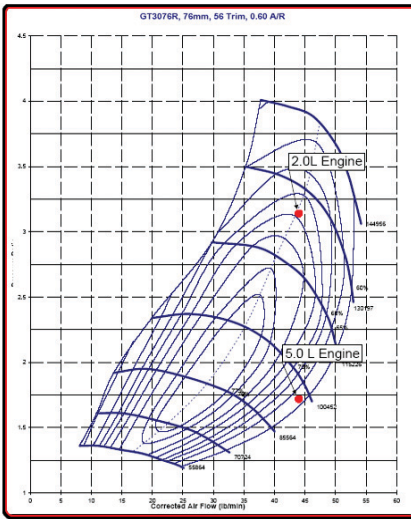

$$Wa = \frac{MAP * VE * N / 2 * Vd}{R * (460 + T_m)}$$

We'll choose the engine speed at which we would expect to see peak torque, based on experience or an educated guess. In this case we'll choose 5000rpm.

Where:

- Wa = Airflow actual (lb/min)
- MAP = Manifold Absolute Pressure (psia) = 35.1 psia
- R = Gas Constant = 639.6
- Tm = Intake Manifold Temperature (degrees F) = 130
- VE = Volumetric Efficiency = 0.98
- N = Engine speed (RPM) = 5000rpm
- Vd = engine displacement (Cubic Inches, convert from liters to CI by multiplying by 61, ex. 2.0 liters * 61 = 122 CI)

$$Wa = \frac{43.1 * 0.98 * 5000 / 2 * 122}{639.6 * (460 + 130)} = 34.1 \text{ lb/min}$$

Plotting this on the GT3071R compressor map demonstrates the following operating points.

This provides a good representation of the operating line at that boost level, which is well suited to this map. At engine speeds lower than 5000 rpm the boost pressure will be lower, and the pressure ratio would be lower, to keep the compressor out of surge.

Back to the 5.0L engine. Let's look at a larger compressor's map. This time we will try a GT3582R with an 82mm, 56 trim compressor.

Here, compared to the GT3076R, we can see that this point is not quite so deep into choke and will give better high-rpm performance than the 76mm wheel. A further increase in wheel size would provide even better high-rpm performance, but at the cost of low- and mid-range response and drivability.

Hopefully this provided a basic idea of what a compressor map displays and how to choose a compressor. If real data is available to be substituted in place of estimation, more accurate results can be generated.

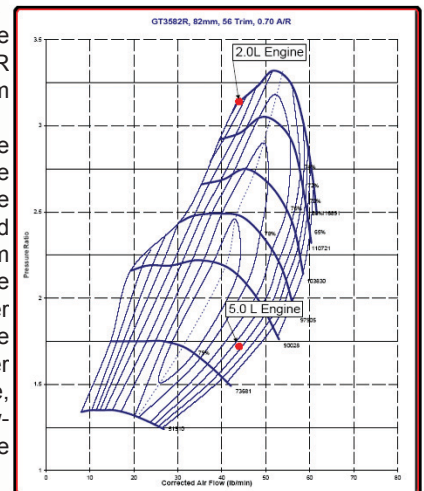
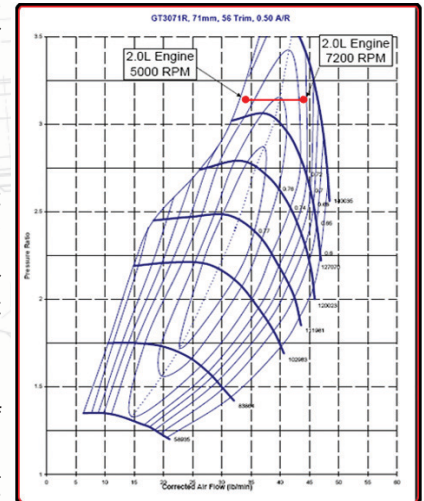

Turbo Selection - Diesel

Garrett®

The Correct Way to Choose a Turbo
Directly From the Garrett® Engineers

Today's diesel engines represent the state of the art in technology with high power density, excellent drivability, and good fuel economy. Fortunately for the diesel enthusiast, they are easier to upgrade for additional performance and the aftermarket is responding with more options for your high performance needs. As the major air system component, the turbocharger is a vital part of the performance equation and choosing the right turbo is critical to meeting your performance targets.

So why would I want to upgrade my Turbo Diesel engine?

Better towing performance -- Maybe you bought your truck to tow that gooseneck for work, to get your 5th wheel to the next resort or your boat to the lake. It sure would be nice to get up to freeway speeds quickly and maintain highway speeds in hilly terrain. With the right upgrades, that can be done safely and efficiently.

Competition Use -- More and more enthusiasts are interested in heavily modifying their vehicles for competition use. Some are weekend warriors that use their vehicles during the week for routine duty then go to the track on the weekends while others are building strictly race vehicles that give up streetability for the demands of the track.

More fun -- For many, making modifications for increased performance is a way of personalizing the vehicle and to have a bit more fun with the daily drive. There is a satisfaction that comes from modifications that put you back into your seat a little harder when the light turns green. And, there are always the grudge matches at the local drag strip.

What do I need to know to choose the right diesel upgrade turbocharger?

The amount of power that a diesel engine makes is directly proportional to the amount of fuel injected into the cylinder and that fuel needs sufficient air for complete combustion. For smoke-free performance, the engine needs about 18 times more air (by mass) than fuel. So clearly, as more fuel is added, additional air needs to be added also. In most applications, the stock turbo has some additional capacity for increased power, but as the compressor reaches the choke limit (maximum flow), the turbo speed increases rapidly, the efficiency drops dramatically, and the compressor discharge temperature ramps up very quickly. This creates a "snowball" effect in that the higher discharge temps mean higher intake manifold temps and higher exhaust gas temps. The lower efficiency means that more turbine power is required to reach the same boost causing higher back pressure in the exhaust manifold. This can usually be seen on an engine with a performance chip (at the highest power setting) and maybe an intake or exhaust upgrade. Under heavy acceleration, smoke is pouring from the tailpipe as the EGT's and turbo speeds are climbing into the danger zone requiring a prudent driver to back off the accelerator pedal early to keep from damaging the engine. Under these conditions, the stock turbo is running on borrowed time. With an upgrade turbocharger selected to compliment the extra fuel, smoke is drastically reduced, EGT's are under control and, since the turbo is operating in a more efficient range, horsepower and drivability are enhanced. When the modifications get more serious, a bigger turbo is a must-have to compliment even more fuel.

In order to decide on the appropriate turbocharger for your diesel engine, the very first thing that needs to be established is the power target. Since turbochargers are sized by how much air they can deliver and airflow is proportional to engine power, a realistic horsepower goal is critical to make the right choice.

The concept of a realistic goal needs to be stressed in order to ensure maximum performance and satisfaction. Sure, everyone would like to have a mega-horsepower vehicle but past a reasonable limit, as the power goes up, the reliability, drivability and day-to-day utility is diminished. Things are more likely to go wrong, wear out and break down as the power output climbs.

Most project vehicles fall into one of the following general categories:

Intended Use	Approximate Power Increase Over Stock	Important Factors
Daily Driver Work Truck Tow Vehicle	+ 150 Horsepower	Reliability, Reduced EGTs, Drivability, Performance, Low Smoke
Weekend Warrior	+ 250 Horsepower	Still needs to pull regular duty during the week and have fun on weekends
Extreme Performance	+ 350 Horsepower	Street driven, but everyday drivability compromised for high performance
Competition	+ 400 Horsepower and up	100% performance, no compromises

Great, So what turbo do I choose?

Let's take each case and calculate a turbo choice based on the intended power increase. The first step is to read the catalog section "Turbo Selection - Gasoline" (pages 8-11). This article explains the reading of a compressor map and the equations needed to properly match a turbo. The examples given, however, are for gasoline engines, so the additional examples here will be using those same equations but with a diesel engine. Matches will be calculated with an Air Fuel Ratio (AFR) of 22:1 for low or no smoke performance. Likewise a typical Brake Specific Fuel Consumption (BSFC) is in the range of 0.38. Let's get started!

The first example will be for the **Daily Driver/Work Truck/Tow Vehicle** category. This includes vehicles up to 150HP over stock. But wait, this power level can be accomplished with just a chip or tuning module. So why bother with a new upgrade turbo? An upgrade turbo will enhance the gains made by installing the chip and other upgrades. The extra air and lower backpressure provided by the upgrade turbo will lower EGTs, allow more power with less smoke and address durability issues with the stock turbo at higher boost pressures and power levels. Because this will be a mild upgrade, boost response and drivability will be improved across the board.

EXAMPLE:

I have a 6.6L diesel engine that makes a claimed 325 flywheel

Turbo Selection - Diesel

The Correct Way to Choose a Turbo
Directly From the Garrett® Engineers

horsepower (about 275 wheel Horsepower as measured on a chassis dyno). I would like to make 425 wheel HP; an increase of 150 wheel horsepower. Plugging these numbers into the formula and using the AFR and BSFC data from above:

Recall from Turbo Selection - Gasoline:

Where:

- Wa = Airflow actual (lb/min)
- HP = Horsepower Target
- A/F = Air/Fuel Ratio
- BSFC/60 = Brake Specific Fuel Consumption ($\frac{lb}{Hp \cdot hr}$) ÷ 60 (to convert from hours to minutes)

$$Wa = 425 * 22 * \frac{0.38}{60} = 59.2 \frac{lb}{min} \text{ of air.}$$

So we will need to choose a compressor map that has a capability of at least 59.2 pounds per minute of airflow capacity. Next, how much boost pressure will be needed?

Calculate the manifold pressure required to meet the horsepower target.

$$MAP_{req} = \frac{Wa * R * (460 + T_m)}{VE * \frac{N}{2} * V_d}$$

Where:

- MAPreq = Manifold Absolute Pressure (psia) required to meet the horsepower target
- Wa = Airflow actual (lb/min)
- R = Gas Constant = 639.6
- Tm = Intake Manifold Temperature (degrees F)
- VE = Volumetric Efficiency
- N = Engine speed (RPM)
- Vd = engine displacement (Cubic Inches, convert from liters to CI by multiplying by 61, ex. 2.0 liters*61 = 122 CI)

For our project engine:

- Wa = 59.2 lb/min as previously calculated
- Tm = 130 degrees F
- VE = 98%
- N = 3300 RPM
- Vd = 6.6 liters * 61 = 400 CI

$$MAP_{req} = \frac{59.2 * 639.6 * (460 + 130)}{.98 * \frac{3300}{2} * 400} = 34.5 \text{ psia (remember, this is Absolute Pressure; subtract Atmospheric Pressure to get Gauge Pressure, } 34.5 \text{ psia} - 14.7 \text{ psia (at sea level) = } 19.8 \text{ psig).}$$

So now we have a Mass Flow and Manifold Pressure. We are almost ready to plot the data on the compressor map. Next step is to determine how much pressure loss exists between the compressor and the manifold. The best way to do this is to measure the pressure drop with a data acquisition system, but many times that is not practical. Depending upon flow rate and charge air cooler size, piping size and number/quality of the bends, throttle body restriction, etc., you can estimate from 1 psi (or less) up to 4 psi (or higher). For our examples we will estimate that there is a 2 psi loss. Therefore we will need to add 2 psi to the manifold pressure in order to determine the Compressor Discharge Pressure (P2c).

Where:

$$P_{2c} = MAP + \Delta P_{loss}$$

- P2c = Compressor Discharge Pressure (psia)
- MAP = Manifold Absolute Pressure (psia)
- ΔPloss = Pressure loss between the Compressor and the Manifold (psi)
- P2c = 34.5 + 2 = 36.5 psia

To get the correct inlet condition, it is now necessary to estimate the air filter or other restrictions. In the Pressure Ratio discussion earlier we said that a typical value might be 1 psi, so that is what will be used in this calculation. Also, we are going to assume that we are at sea level, so we are going to use an ambient pressure of 14.7 psia. We will need to subtract the 1 psi pressure loss from the Ambient Pressure to determine the Compressor Inlet Pressure (P1c).

$$P_{1c} = P_{amb} - \Delta P_{loss}$$

Where:

- o P1c = Compressor Inlet Pressure (psia)
- o Pamb = Ambient Air pressure (psia)
- o ΔPloss = Pressure loss due to Air Filter/Piping (psi)
- P1c = 14.7 - 1 = 13.7 psia

With this, we can calculate Pressure Ratio () using the equation.

$$\Pi_c = \frac{P_{2c}}{P_{1c}}$$

For the 2.0L engine:

$$\Pi_c = \frac{36.5}{13.7} = 2.7$$

We now have enough information to plot these operating points on the compressor map. First we will try a GT3788R. This turbo has an 88mm tip diameter 52 trim compressor wheel with a 64.45mm inducer.

As you can see, this point falls nicely on the map with some additional room for increased boost and mass flow if the horsepower target climbs. For this reason, the GT37R turbo family is applied on many of the Garrett® PowerMax™ turbo kits that are sized for this horsepower range.

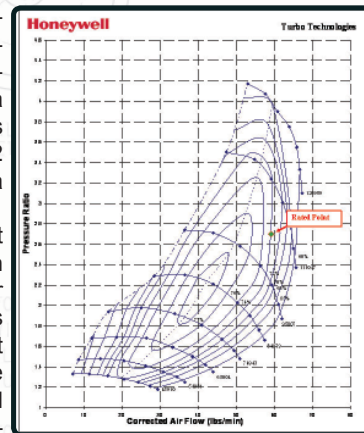

For the next example, let's look at the **Weekend Warrior**. This category is for daily driven vehicles that have up to 250 horsepower over stock or 525 wheel horsepower.

Plugging that power target into our formula yields an airflow requirement of:

$$Wa = 525 * 22 * \frac{0.38}{60} = 73.2 \frac{lb}{min} \text{ of air flow.}$$

And a pressure ratio of:

$$MAP_{req} = \frac{73.2 * 639.6 * (460 + 130)}{.98 * \frac{3300}{2} * 400} = 43.5 \text{ psia}$$

Turbo Selection - Diesel

The Correct Way to Choose a Turbo Directly From the Garrett® Engineers

Garrett®

$$P_{2c} = 43.5 + 2 = 45.5 \text{ psia}$$

$$\Pi_c = \frac{45.5}{13.7} = 3.3$$

Looking at the previous map, the compressor does not flow enough to support this requirement, so we must look at the next larger size compressor. (Technically, the engine could probably easily make this power with the previous compressor, but it would be at risk of more smoke, higher EGT's and backpressure; kind of like pushing a stock compressor too far...) The next larger turbo is a Garrett® GT4094R. Another option that could also be considered is the GT4294R which has a slightly larger inducer compressor and the next larger frame size turbine wheel. The larger wheel's inertia will slow down the response a bit, but provide better performance at the top end of the rpm range.

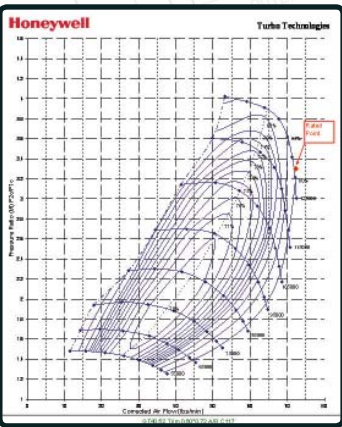

For the next example, let's look at the **Extreme Performance**. This category is for real hot rod vehicles that have up to 350 horsepower over stock and owners that are willing to give up some of the daily utility in order to achieve higher power gains.

Plugging that power target into our formula yields an airflow requirement of:

$$W_a = 625 * 22 * \frac{0.38}{60} = 87.1 \text{ lb/min of air}$$

And a pressure ratio of:

$$MAP_{req} = \frac{87.1 * 639.6 * (460 + 130)}{98 * 3300 / 2 * 400} = 50.8 \text{ psia}$$

$$P_{2c} = 50.8 + 2 = 52.8 \text{ psia}$$

$$\Pi_c = \frac{52.8}{13.7} = 3.8$$

For this flow and pressure ratio, the GT4202R is appropriate and is shown below. Since this is approaching a pressure ratio of 4-to-1, we are about at the limit of a single turbo on an engine of this size.

Additional power gains can be had with more boost or a larger single turbo, but it is getting close to the edge of the envelope in terms of efficiency and turbo speed.

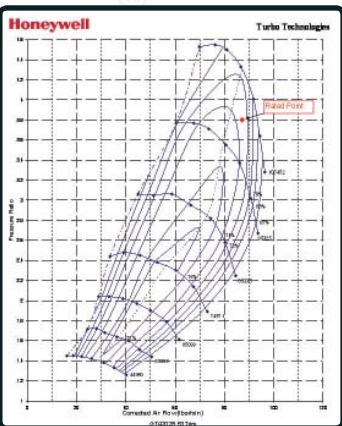

The final case is the **Competition** category. Since this is a special case and there are so many ways to go about an ultimate power diesel application, it is not possible to cover it adequately in this article. There are, however, some general guidelines. At this power level, as stated above, it is a good idea to consider a series turbo application. This

is a situation where one turbo feeds another turbo, sharing the work of compressing the air across both compressors. A larger turbo is designated as the "low-pressure" turbo and the smaller secondary stage as the "high pressure" turbo. The low-pressure compressor feeds the high-pressure compressor which then feeds the intake. On the turbine-side the exhaust first passes through the high-pressure turbine and then on to the low-pressure turbine before being routed out through the tailpipe. We can still calculate the required mass flow, but the pressure ratio is more involved and questions should be discussed with your local Garrett® PowerMax™ distributor. To calculate the required mass flow, we use the normal equation. This time the power target will be 500 wheel horsepower over stock, for a total of 775 wheel horsepower.

$$W_a = 775 * 22 * \frac{0.38}{60} = 108 \text{ lb/min of air flow.}$$

This air flow rate will apply only to the low-pressure compressor as the high-pressure compressor will be smaller because it is further pressurizing already compressed air. In most cases, the high-pressure turbo tends to be about two frame sizes smaller than the low pressure stage. So in this case, after selecting the appropriate low-pressure turbo (hint: look at the GT4718R compressor map), a GT4088R or GT4094R would be the likely candidates.

One more comment on choosing a properly sized turbine housing A/R. A smaller A/R will help the turbo come up on boost sooner and provide a better responding turbo application, but at the expense of higher back pressure in the higher rpm zones and, in some cases, a risk of pushing the compressor into surge if the boost rises too rapidly. On the other hand, a larger A/R will respond slower, but with better top end performance and reduced risk of running the compressor into surge. Generally speaking, the proper turbine housing is the largest one that will give acceptable boost response on the low end while allowing for more optimal top end performance.

This information should be used as a starting point for making decisions on proper turbo sizing. For more specific information on your engine, consult a Garrett® PowerMax™ Distributor. Find your Garrett® PowerMax™ Distributor at www.TurboByGarrett.com.

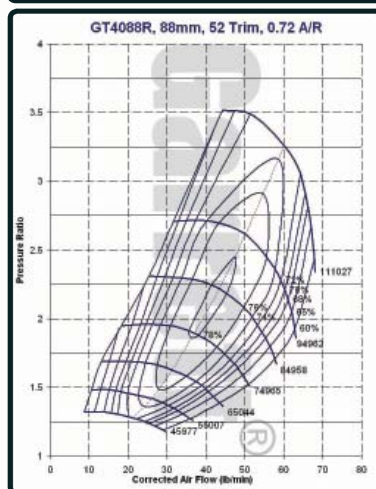
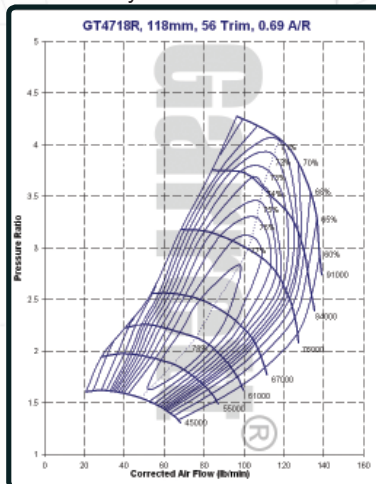

Troubleshooting

Repair and Rebuild

When Good Boost Goes Bad

Troubleshooting

Nearly all turbocharger-related problems are the result of a handful of causes. Knowing how to recognize the symptoms of these issues early and link them with causes will help you save (down) time and money.

The chart below outlines the probable causes and

noticeable conditions of the most common turbocharger maladies as well as what you can do to solve them.

By using this chart, most turbocharger problems can be easily identified and rectified. However, if a problem falls outside of your comfort level for service, contact a Garrett® Performance Distributor or a Garrett® Master Distributor for assistance.

Turbocharger Troubleshooting	Symptoms	Possible Cause										Solutions	
		Engine Lacks Power	Black Smoke	Excessive Oil Consumption	Blue Smoke	Excessive Oil - Compressor End	Excessive Oil - Turbine End	Drag or Bind in Rotating Assembly	Excessive Rotating Assembly Play	Damaged Compressor Wheel	Damaged Turbine Wheel		
Dirty air cleaner element		■	■	■	■	■	■	■	■	■	■	■	Clean or replaced filter element
Plugged crankcase breathers		■	■	■	■	■	■	■	■	■	■	■	Clear obstruction per manufacturer's manual
Air cleaner element missing, leaking or loose connections to turbo		■	■	■	■	■	■	■	■	■	■	■	Replace, repair or reconnect air cleaner element per manufacturer's manual
Collapsed or restricted air pipe before turbocharger		■	■	■	■	■	■	■	■	■	■	■	Inspect pipe for damage or obstructions, replace or repair
Restricted or damaged cross-over pipe - turbo to inlet manifold		■	■	■	■	■	■	■	■	■	■	■	Inspect pipe for damage or obstructions, replace or repair
Foreign object between cleaner and turbocharger		■	■	■	■	■	■	■	■	■	■	■	Inspect air intake piping, remove foreign object
Foreign object in exhaust system (from engine, check engine)		■	■	■	■	■	■	■	■	■	■	■	Inspect exhaust piping ONLY when engine is NOT running and cold, remove foreign object
Turbocharger flanges, clamp or bolts loose		■	■	■	■	■	■	■	■	■	■	■	Inspect all connecting hardware for damage, ensure tight fits per installation instructions
Inlet manifold cracked, gaskets loose or missing, connections loose		■	■	■	■	■	■	■	■	■	■	■	Remove and inspect inlet manifold for damage to castings and gaskets, replace if needed
Exhaust manifold cracked, burned, gasket loose, blown or missing		■	■	■	■	■	■	■	■	■	■	■	Remove exhaust manifold ONLY when engine is cold and NOT running and inspect for damage to castings and gaskets, replace if needed
Restricted exhaust system		■	■	■	■	■	■	■	■	■	■	■	Inspect exhaust system ONLY when engine is cold, NOT running, remove obstruction
Oil lag at start-up		■	■	■	■	■	■	■	■	■	■	■	Inspect lubrication system lines, filters, and oil for obstruction, remove obstruction
Insufficient lubrication		■	■	■	■	■	■	■	■	■	■	■	Inspect lubrication system lines, filters, and oil for obstruction, remove obstruction
Lubricating oil contaminated with dirt or other material		■	■	■	■	■	■	■	■	■	■	■	Replace all filters and lubricating oil with new per manufacturer's manual
Improper lubricating oil type used		■	■	■	■	■	■	■	■	■	■	■	Replace lubricating oil with correct grade
Restricted oil feed line		■	■	■	■	■	■	■	■	■	■	■	Remove and inspect oil line, remove obstruction
Restricted oil drain line		■	■	■	■	■	■	■	■	■	■	■	Remove and inspect oil line, remove obstruction
Turbine housing damaged or restricted		■	■	■	■	■	■	■	■	■	■	■	Remove turbine housing, inspect for cracks or wear, replace if needed
Turbocharger seal leakage		■	■	■	■	■	■	■	■	■	■	■	Inspect for proper oil feed / drain line installation. Contact a Garrett® Performance Distributor or a Garrett® Master Distributor for a rebuild
Worn journal bearing		■	■	■	■	■	■	■	■	■	■	■	Contact a Garrett® Performance Distributor or Garrett® Master Distributor
Excessive dirt build-up behind turbine wheel		■	■	■	■	■	■	■	■	■	■	■	Inspect air cleaner element and intake piping for damage or leaks, replace if needed. Clean compressor wheel and housing
Excessive carbon build-up on compressor housing		■	■	■	■	■	■	■	■	■	■	■	Inspect crankcase ventilation system
Too fast acceleration at initial start		■	■	■	■	■	■	■	■	■	■	■	Decrease acceleration at initial start
Too little warm-up time		■	■	■	■	■	■	■	■	■	■	■	Extend warm-up period
Fuel pump malfunction		■	■	■	■	■	■	■	■	■	■	■	Refer to engine manufacturers manual and replace if needed
Worn or damaged injectors		■	■	■	■	■	■	■	■	■	■	■	Inspect injectors for damage and replace if needed
Valve timing		■	■	■	■	■	■	■	■	■	■	■	Refer to engine manufacturers manual and adjust as needed
Burned valves		■	■	■	■	■	■	■	■	■	■	■	Refer to engine manufacturers manual and replace if needed
Worn piston rings		■	■	■	■	■	■	■	■	■	■	■	Refer to engine manufacturers manual and replace if needed
Burned pistons		■	■	■	■	■	■	■	■	■	■	■	Refer to engine manufacturers manual and replace if needed
Leaking oil feed line		■	■	■	■	■	■	■	■	■	■	■	Remove and inspect oil line, remove obstruction
Excessive engine pre-oil		■	■	■	■	■	■	■	■	■	■	■	Refer to engine manufacturers manual and adjust as needed
Excessive engine idle		■	■	■	■	■	■	■	■	■	■	■	Refer to engine manufacturers manual and adjust as needed
Coked or sludged center housing		■	■	■	■	■	■	■	■	■	■	■	Contact a Garrett® Performance Distributor or Garrett® Master Distributor
Oil pump malfunction		■	■	■	■	■	■	■	■	■	■	■	Refer to engine manufacturers manual and replace if needed
Oil filter plugged		■	■	■	■	■	■	■	■	■	■	■	Refer to engine manufacturers manual and replace if needed
Oil bath air cleaner: air inlet screen restricted / dirty air cleaner		■	■	■	■	■	■	■	■	■	■	■	Replace air inlet screen
Oil bath air cleaner: oil pull-over / oil viscosity too low or high		■	■	■	■	■	■	■	■	■	■	■	Replace lubricating oil with correct grade
Boost control malfunction: wastegate		■	■	■	■	■	■	■	■	■	■	■	Inspect for damage, leaks or obstructions; replace or repair if needed
Boost control malfunction: VNT		■	■	■	■	■	■	■	■	■	■	■	Contact a Garrett® Performance Distributor or a Garrett® Master distributor
Boost control malfunction: engine management system		■	■	■	■	■	■	■	■	■	■	■	Refer to manufacturers manual and adjust as needed

Displacement Chart

Turbocharger Families
Performance Ranges

Garrett®

Garrett® Turbocharger Displacement Chart

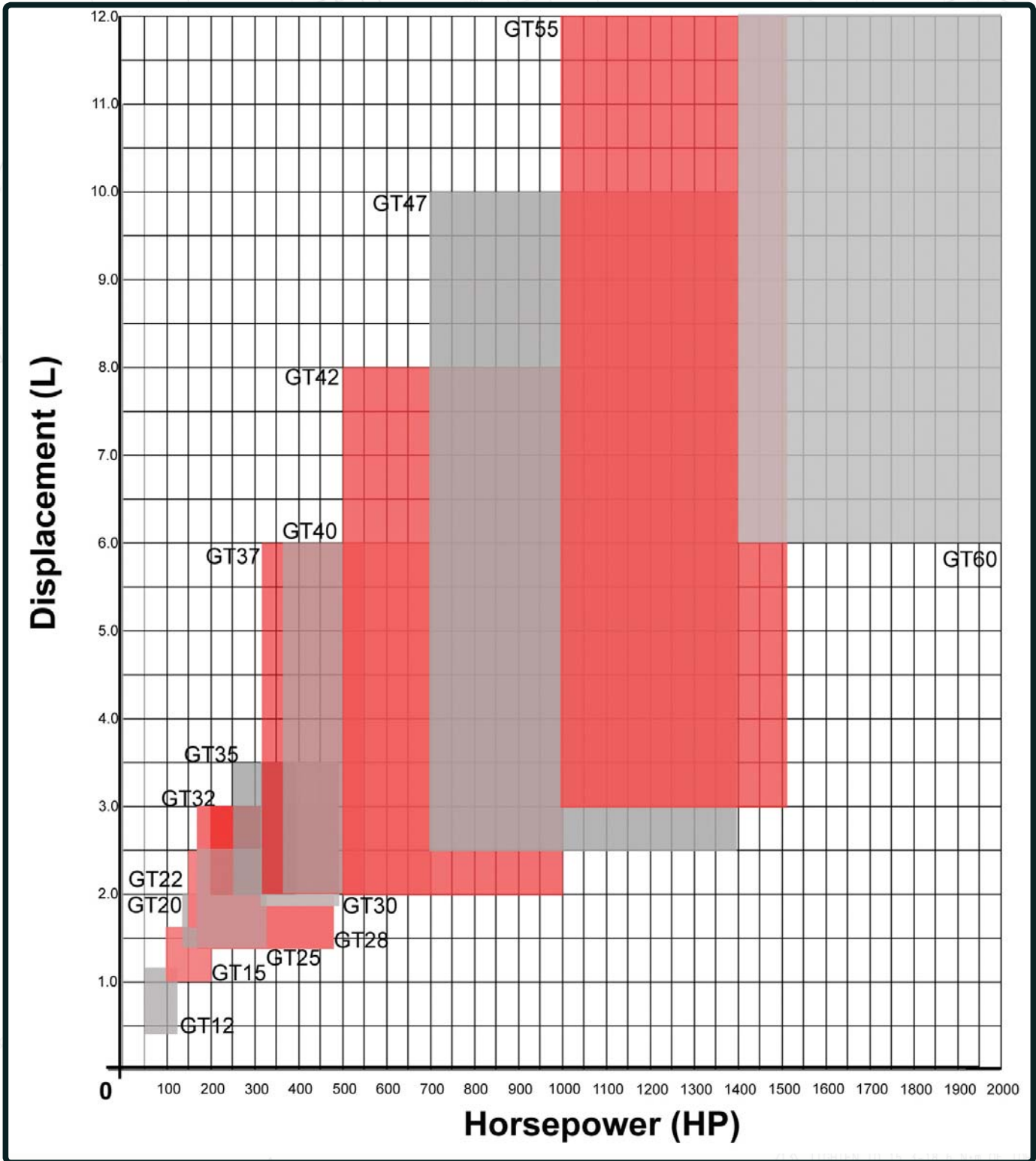

Chart represents approximations. See your Garrett® distributor for proper sizing.

pursuit of power

Garrett® Turbochargers

Turbochargers
Aerodynamically Advanced GT Wheels
Dual Ball Bearing Center Sections

TURBOCHARGERS

Proven performance

The Garrett® dual ball bearing cartridge has proven its worth in the highest level of motorsports where it has been the bearing system of choice in everything from the 24 Hours of Le Mans to drag racing. These premier racing customers demand no less than the best in durability, reliability, and power on demand. One key contributor to this performance lies in the ball bearing cartridge where it is, by design, surrounded by a thin film of oil. The oil film damps out destructive vibrations that would otherwise compromise turbo durability.

A clear demonstration of the inherent superiority of the Garrett® ball bearing design is in the launch of a turbocharged drag race car. The two-step rev limiters used to build boost on the line expose the turbo to the harshest imaginable conditions of pressure spikes and scorching temperatures. Where lesser turbos often fail catastrophically, Garrett® ball bearing turbos regularly shrug off these brutal conditions time after time. In fact, many drag racers running Garrett® ball bearing turbos have not needed to rebuild or replace their turbos for multiple seasons. Can you say that about your turbo?

Combined with the aerodynamically advanced Garrett® GT wheel design, Garrett® GT ball bearing turbos provide improved drivability and power on demand.

Garrett® GT-Series Turbochargers - the standard by which all others are judged.

Small Frame

GT12 - GT15 - GT20 - GT22

The fun starts here. A range of modern wastegated turbochargers ideally suited for small-displacement applications including motorcycles, snowmobiles and more.

Medium Frame

GT25 - GT28 - GT30 - GT32 - GT35

A huge selection of journal bearing turbos, housing options, and our proven, patented ball-bearing turbos. Wastegated or free-floating; from the quick-spooling GT2560R to the competition-crushing GT3582R, you'll find your best options here whether you want 170 hp or 550 hp.

Large Frame

GT37 GT40 GT42 GT45 GT47
GT55 GT60

Best suited for large-displacement engines, drag racing vehicles, and other applications that require significant airflow. There are wastegated or free-floating units here, plus our exclusive large-frame ball-bearing CHRAs.

Using the Garrett® Turbo Guide

This catalog provides images and descriptions of a representative of each family in the Garrett® GT line. Compressor maps are provided to assist in sizing your Garrett® GT turbo to your engine and turbine maps are provided at www.TurboByGarrett.com. This guide also gives you the inlet and outlet geometry drawings for every turbo represented. Be aware that some turbo family members not appearing in this catalog may have different flanges. References to these drawings are found in the Flange Dimensions table on each page and are linked to the Sizes & Dimensions index beginning on page 47 by the numbering system of page number - drawing number.

Ball Bearing Service Program

A great deal of pride is taken in the quality of Garrett® turbochargers and they are tested extensively. However, sometimes the unthinkable happens and a turbo fails. A new option now provides for the exchange of a failed or used Garrett® CHRA for credit on a new CHRA at an affordable price!

The program requires you take the following steps:

1. Make sure your unit is covered by the program by checking the Ball Bearing Service Chart on www.TurboByGarrett.com.
2. Send your used CHRA* to a Garrett® Performance Distributor for inspection.
3. Purchase a new CHRA at a discounted price!

*At a minimum, the center housing must be re-usable to qualify for this program. The Garrett Performance Distributor will determine the condition upon receiving the CHRA and has final say in the applicability of a CHRA for this program.

Visit www.TurboByGarrett.com To see the entire Garrett® GT-Series line of turbochargers and to get the latest turbo product, tutorials and racing updates.

pursuit of power

Turbochargers > Small Frame > GT12

GT1241

Journal Bearing
Oil & Water-Cooled CHRA



- Smallest Garrett® turbocharger available
- Excellent for motorcycles or other small displacement engines
- Internally wastegated turbine housing, complete with actuator

APPLICATION

Horsepower 50 - 130
Displacement 0.4L - 1.2L

FLANGE DIMENSIONS

Component	Inlet		Outlet	
	Page	Diagram	Page	Diagram
Compressor	47	12	47	09
Turbine	48	07	50	02
Oil	49	10	49	10
Water	51	11	51	11

GT1241

COMPRESSOR

TURBINE

Turbo PN	CHRA PN	Ind Whl Dia	Exd Whl Dia	Trim	A/R	Whl Dia	Trim	A/R	Type
756068-1	757864-1	29.0mm	41.0mm	50	0.33	35.5mm	72	0.43	Wastegated

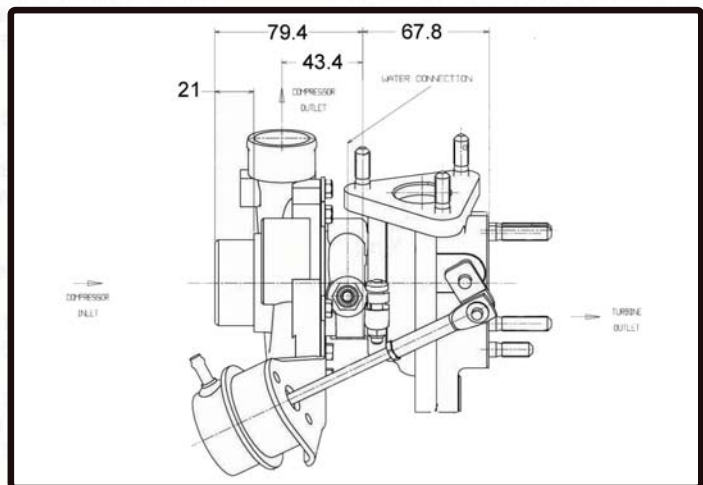
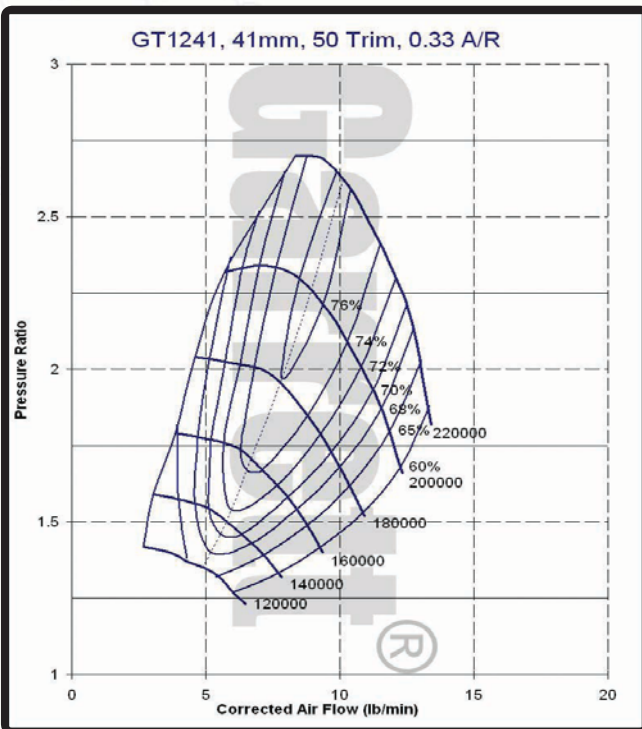

GT1548

Journal Bearing
Oil & Water-Cooled CHRA



- Internally wastegated turbine housing, complete with actuator
- Excellent for motorcycles and other small displacement engines
- More GT15 turbocharger options on page 54 and www.TurboByGarrett.com

APPLICATION

Horsepower 100 - 200
Displacement 1.0L - 1.6L

FLANGE DIMENSIONS

Component	Inlet		Outlet	
	Page	Diagram	Page	Diagram
Compressor	47	15	47	15
Turbine	48	01	50	03
Oil	49	11	49	15
Water	51	12	51	12

GT1548

COMPRESSOR

TURBINE

Turbo PN	CHRA PN	Ind Whl Dia	Exd Whl Dia	Trim	A/R	Whl Dia	Trim	A/R	Type
466755-3	431876-93	37.2mm	48.0mm	60	0.48	41.2mm	72	0.35	Wastegated

GT1548, 48mm, 60 Trim, 0.48 A/R

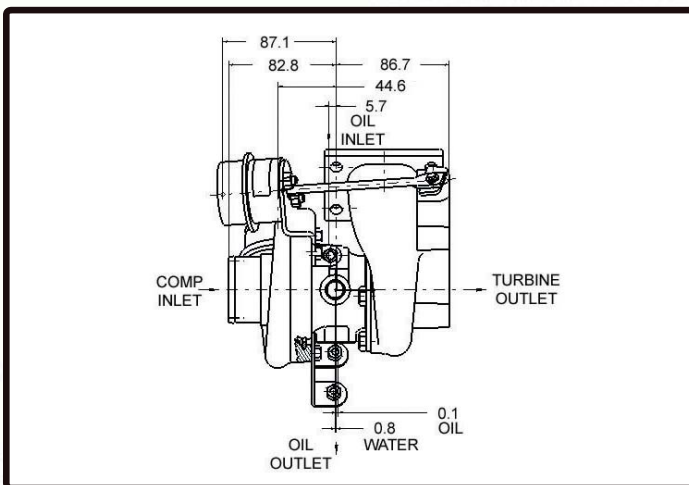
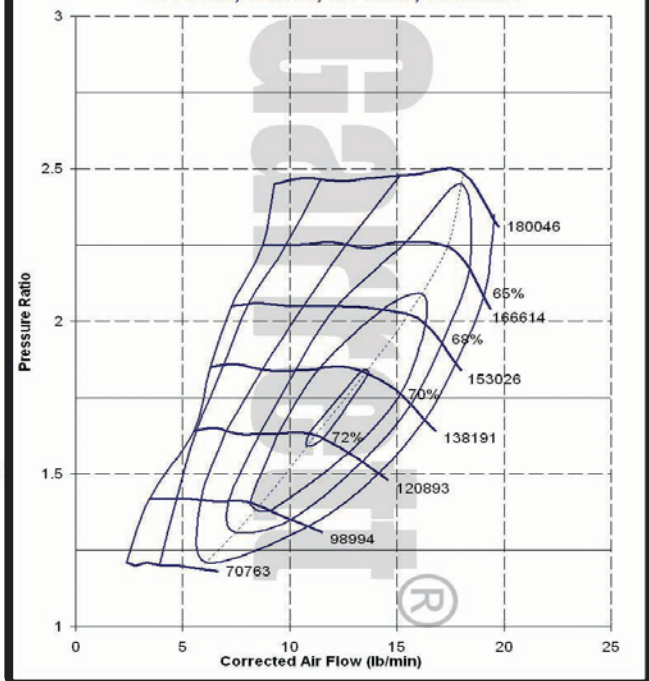

pursuit of power

Turbochargers > Small Frame > GT20

GT2056

Journal Bearing
Oil-Cooled CHRA



- Internally wastegated turbine housing, complete with actuator
- More GT20 turbocharger options on page 54 and www.TurboByGarrett.com

APPLICATION

Horsepower 140 - 260
Displacement 1.4L - 2.0L

FLANGE DIMENSIONS

Component	Inlet		Outlet	
	Page	Diagram	Page	Diagram
Compressor	47	18	47	16
Turbine	48	03	50	08
Oil	See	Note	49	16
Water	-	-	-	-

GT2056

COMPRESSOR

TURBINE

Turbo PN	CHRA PN	Ind Whl Dia	Exd Whl Dia	Trim	A/R	Whl Dia	Trim	A/R	Type
751578-2	433289-234	41.5mm	56.0mm	55	0.53	47.0mm	72	0.46	Wastegated

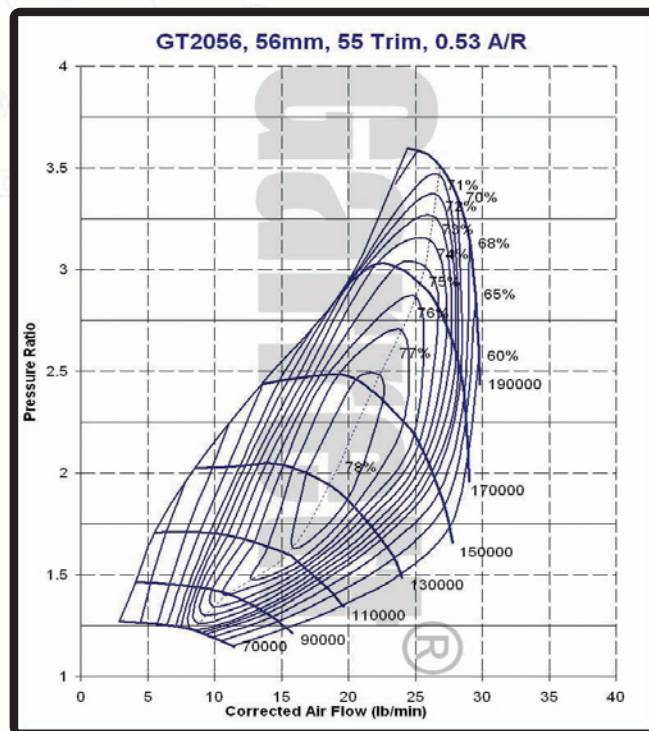

Dimension Note:

Oil Inlet - M10x1.0 (F) or M14x1.0 (M)

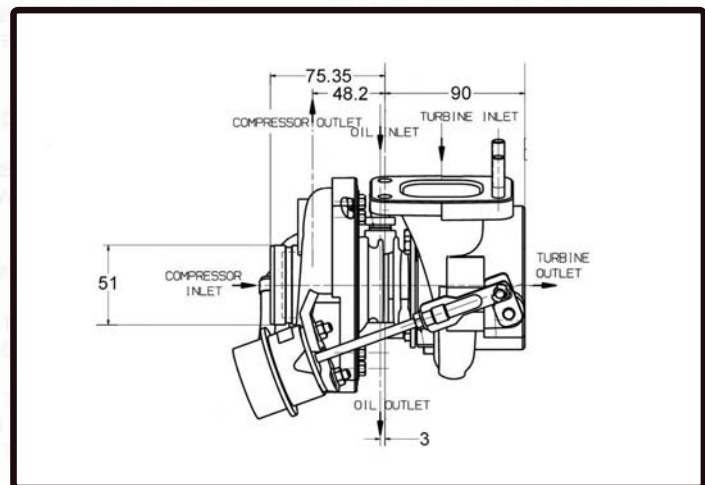

GT2252

Journal Bearing
Oil-Cooled CHRA

Garrett®



- Internally wastegated turbine housing, complete with actuator
- Extremely efficient turbocharger
- Free float turbine housing option available
- **More GT22 turbocharger options on page 54 and www.TurboByGarrett.com**

APPLICATION

Horsepower 150 - 260
Displacement 1.7L - 2.5L

FLANGE DIMENSIONS

Component	Inlet		Outlet	
	Page	Diagram	Page	Diagram
Compressor	47	21	47	15
Turbine	48	01	50	10
Oil	See	Note	49	16
Water	-	-	-	-

GT2252

COMPRESSOR

TURBINE

Turbo PN	CHRA PN	Ind Whl Dia	Exd Whl Dia	Trim	A/R	Whl Dia	Trim	A/R	Type
452187-6	451298-6	40.2mm	52.0mm	60	0.51	50.3mm	72	0.67	Wastegated

TURBINE HOUSING OPTION

PN	Whl Dia	Trim	A/R	Type
451503-1	-	-	0.56	Free Float

Dimension Note:

Oil Inlet - M10x1.0 (F) or M10x1.0 (M)

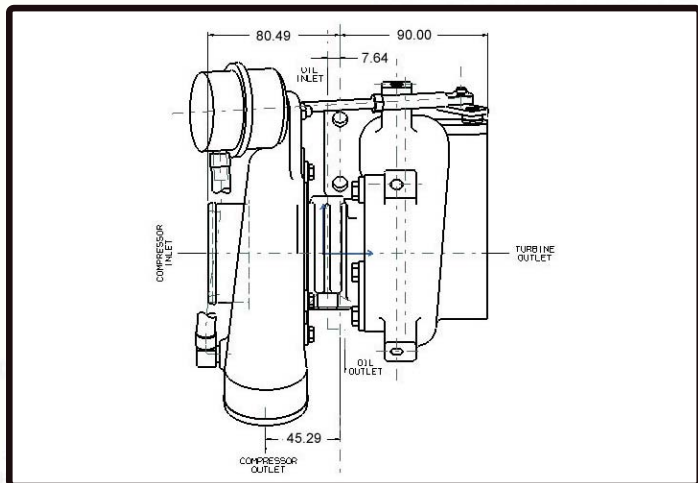
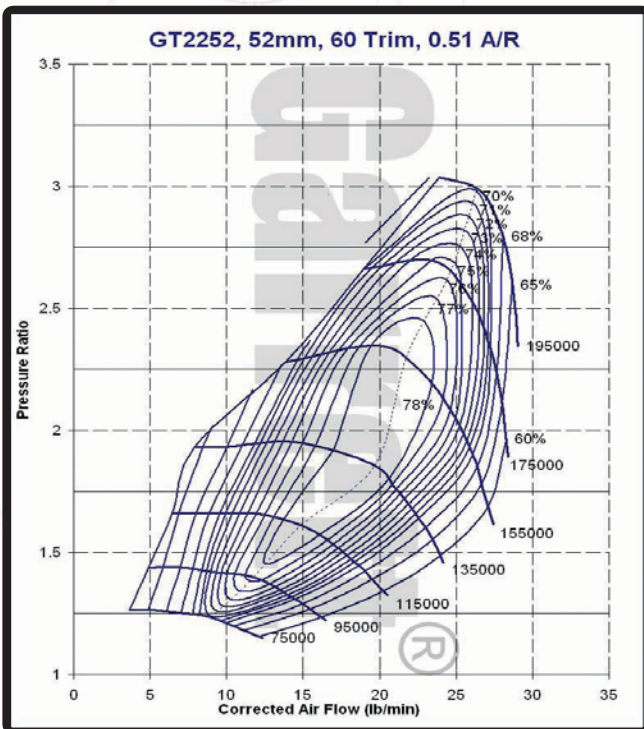

pursuit of power

Turbochargers > Small Frame > GT25

GT2560R

Ball Bearing
Oil & Water-Cooled CHRA



- Internally wastegated turbine housing, complete with actuator
- Turbine housing is cast from high-nickel "Ni-Resist" material (PN 466541-4 only)
- Turbine wheel is cast from "Inconel" material for extreme applications (PN 466541-4 only)
- Upgrade turbo for GT2554R (PN 471171-3); outline interchangeable except compressor inlet
- OEM turbocharger on Nissan SR20DET engine
- **More GT25R turbocharger options on page 54 and www.TurboByGarrett.com**

APPLICATION

Horsepower 200 - 330
Displacement 1.6L - 2.5L

FLANGE DIMENSIONS

Component	Inlet		Outlet	
	Page	Diagram	Page	Diagram
Compressor	47	02	47	04
Turbine	48	01	50	11
Oil	49	11	49	18
Water	51	12	51	12

GT2560R

COMPRESSOR

TURBINE

Turbo PN	CHRA PN	Ind Whl Dia	Exd Whl Dia	Trim	A/R	Whl Dia	Trim	A/R	Type
466541-1	446179-12	46.5mm	60.0mm	60	0.60	53.0mm	62	0.64	Wastegated
466541-4	446179-38	46.5mm	60.0mm	60	0.60	53.0mm	62	0.64	Wastegated

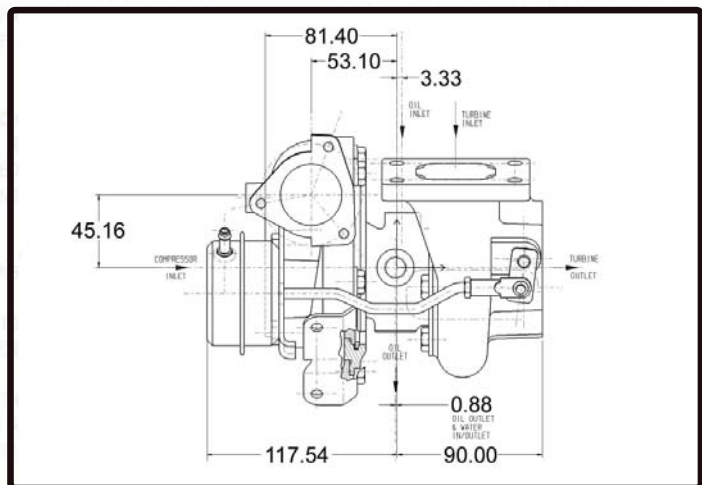
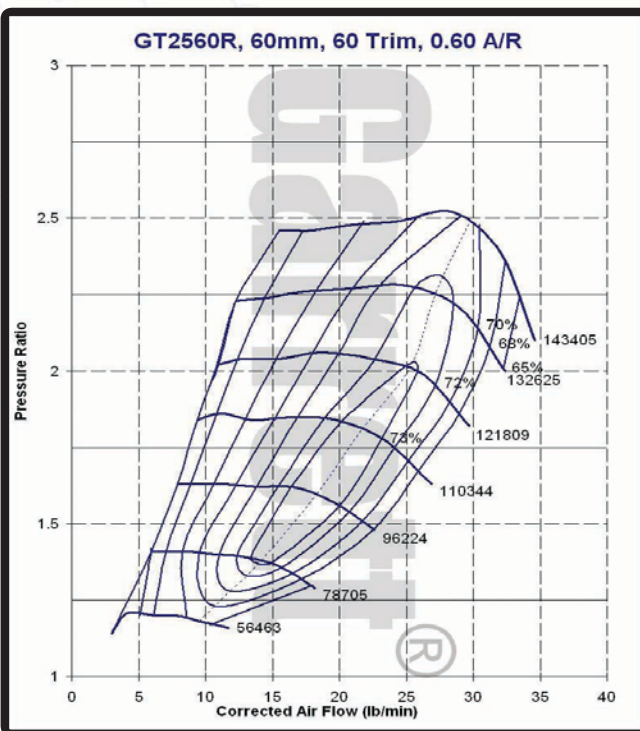

GT2860R

Ball Bearing
Oil & Water-Cooled CHRA

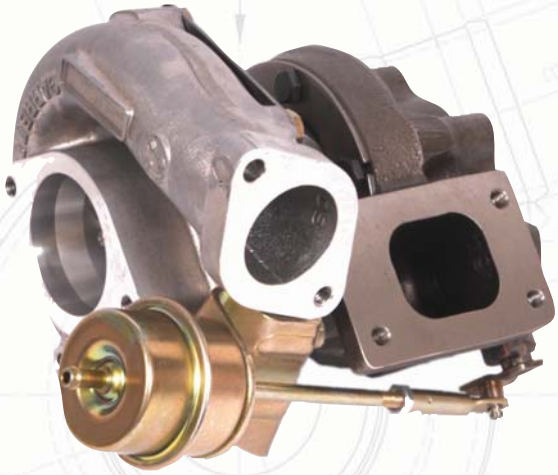

- Internally wastegated turbine housing, complete with actuator
- Turbine housing is cast from "Ni-Resist" material
- Turbine wheel is cast from "Inconel" material for extreme applications
- Turbine housing has a unique "compact" 5-bolt outlet that is not interchangeable with traditional T25 5-bolt outlets
- Direct replacement upgrade turbocharger for Garrett® GT2556R (PN 702987-7) used on R34 Nissan Skyline GT-R
- **More GT2860R turbocharger options on page 54 and www.TurboByGarrett.com**

APPLICATION

Horsepower 250 - 360
Displacement 1.8L - 3.0L

FLANGE DIMENSIONS

Component	Inlet		Outlet	
	Page	Diagram	Page	Diagram
Compressor	47	02	47	01
Turbine	48	02	50	09
Oil	49	11	49	18
Water	51	12	51	12

GT2860R

COMPRESSOR

TURBINE

Turbo PN	CHRA PN	Ind Whl Dia	Exd Whl Dia	Trim	A/R	Whl Dia	Trim	A/R	Type
707160-5	446179-51	47.2mm	60.0mm	62	0.60	53.8mm	76	0.64	Wastegated

TURBINE HOUSING OPTION

PN	Whl Dia	Trim	A/R	Type
430609-230*	-	-	0.64	Wastegated
430609-231*	-	-	0.86	Wastegated

* Note: Allows 707160-5 turbo to be outline interchangeable with other turbos using the traditional 5-bolt turbine housing. Actuator/wastegate fitment may need adjustment.

GT2860R, 60mm, 62 trim, 0.60 A/R

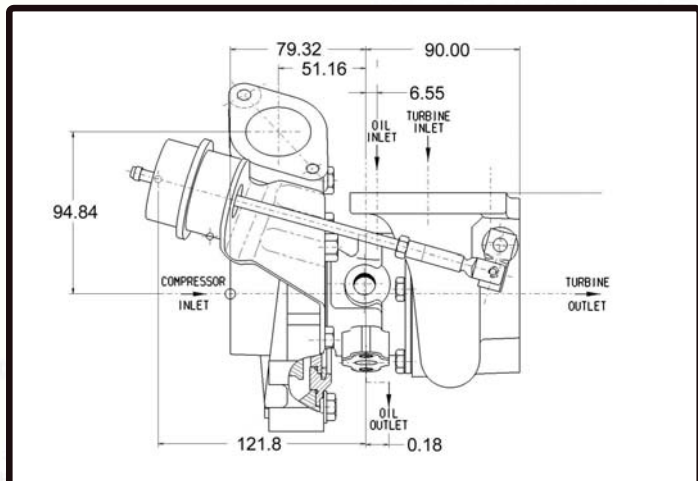
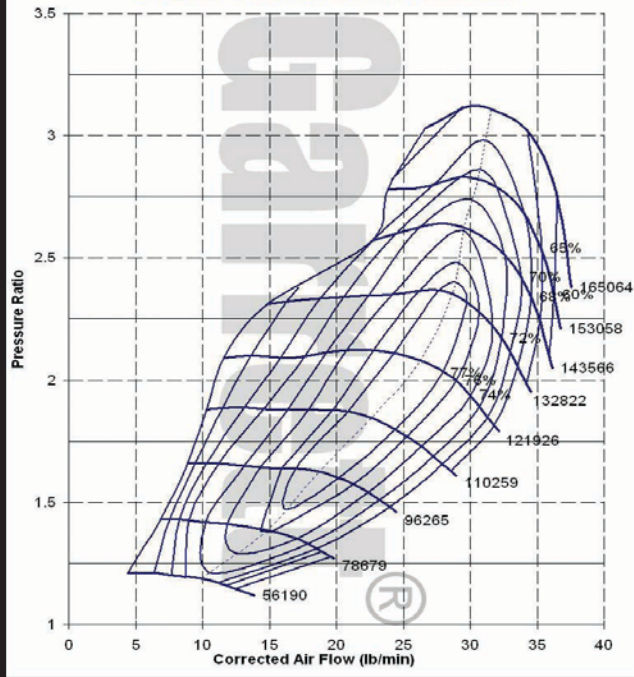

GT2871R

Ball Bearing
Oil & Water-Cooled CHRA

Garrett®



- Internally wastegated turbine housing, complete with actuator
- Direct bolt-on upgrade turbocharger for GT2860RS (PN 739548-1)
- Comes as a kit; end housings are not assembled onto CHRA
- Great size for applications with packaging constraints
- **More GT2871R turbocharger options on page 54 and www.TurboByGarrett.com**

APPLICATION

Horsepower 280 - 475
Displacement 1.8L - 3.0L

FLANGE DIMENSIONS

Component	Inlet		Outlet	
	Page	Diagram	Page	Diagram
Compressor	47	28	47	19
Turbine	48	01	50	11
Oil	49	11	49	18
Water	51	12	51	12

GT2871R

COMPRESSOR

TURBINE

Turbo PN	CHRA PN	Ind Whl Dia	Exd Whl Dia	Trim	A/R	Whl Dia	Trim	A/R	Type
743347-2	449179-32	53.1mm	71.0mm	56	0.60	53.8mm	76	0.86	Wastegated

TURBINE HOUSING OPTION

PN	Whl Dia	Trim	A/R	Type
430609-230	-	-	0.64	Wastegated

COMPRESSOR HOUSING OPTION

PN	Inlet Dia	Outlet Dia	A/R
756021-1	2.75" Hose	2.00" Hose	0.50
756021-2	4.00" Hose	2.00" Hose	0.50

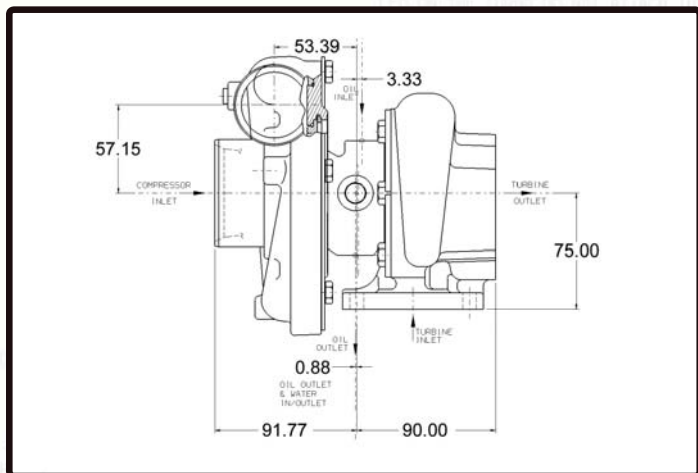
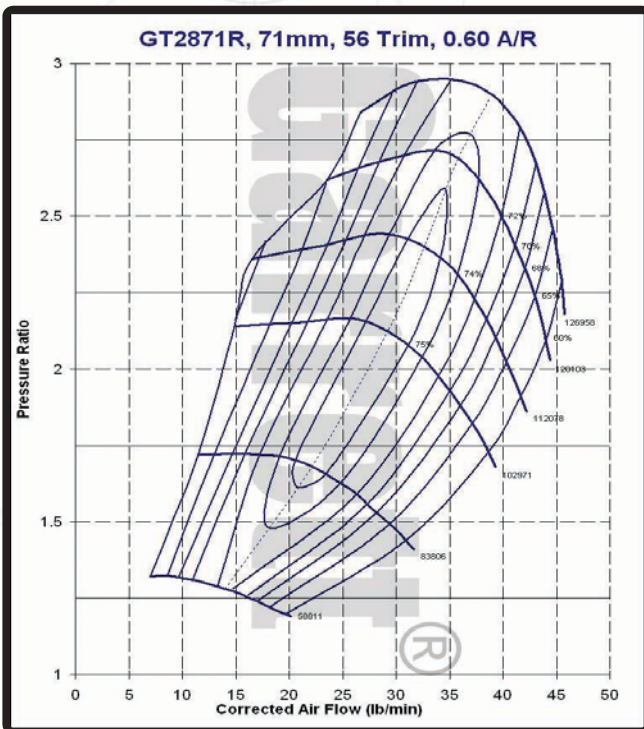

pursuit of power

Turbochargers > Medium Frame > GT28

GT2876R

Ball Bearing
Oil & Water-Cooled CHRA



- Internally wastegated turbine housing, actuator NOT included

APPLICATION

Horsepower 280 - 480
Displacement 1.8L - 3.0L

FLANGE DIMENSIONS

Component	Inlet		Outlet	
	Page	Diagram	Page	Diagram
Compressor	47	35	47	24
Turbine	48	01	50	11
Oil	49	11	49	18
Water	51	12	51	12

GT2876R

COMPRESSOR

TURBINE

Turbo PN	CHRA PN	Ind Whl Dia	Exd Whl Dia	Trim	A/R	Whl Dia	Trim	A/R	Type
705330-1	446179-18	52.7mm	76.0mm	48	0.70	53.8mm	76	0.64	Wastegated
705330-2	446179-18	52.7mm	76.0mm	48	0.70	53.8mm	76	0.86	Wastegated

TURBINE HOUSING OPTION

PN	Whl Dia	Trim	A/R	Type
430609-230	-	-	0.64	Wastegated
430609-231	-	-	0.86	Wastegated

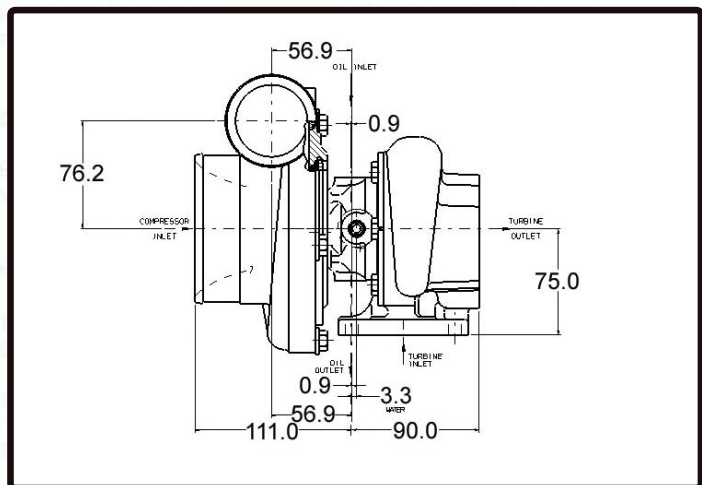
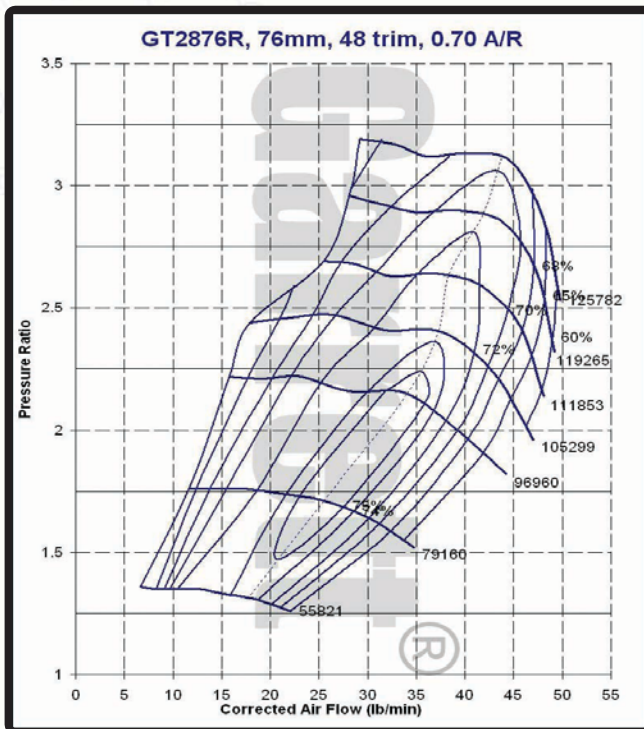

GT3071R

Ball Bearing
Oil & Water-Cooled CHRA

Garrett®



- Internally wastegated turbine housing, actuator NOT included
- This wastegated version of the GT3071R uses specially-modified GT30 turbine wheels for use in the T25-style housing
- Turbine housing flanges are outline interchangeable with GT2554R (PN 471171-3), GT2560R (PN 466541-1) and GT2860RS (PN 739548-1)
- Free float GT3071R turbocharger options available on page 54 and www.TurboByGarrett.com

APPLICATION

Horsepower 310 - 475
Displacement 1.8L - 3.0L

FLANGE DIMENSIONS

Component	Inlet		Outlet	
	Page	Diagram	Page	Diagram
Compressor	See	Note	47	17
Turbine	48	01	50	11
Oil	49	11	49	18
Water	51	12	51	12

GT3071R

COMPRESSOR

TURBINE

Turbo PN	CHRA PN	Ind Whl Dia	Exd Whl Dia	Trim	A/R	Whl Dia	Trim	A/R	Type
700382-3	700177-3	53.1mm	71.0mm	56	0.50	56.5mm	84	0.64	Wastegated
700382-20	700177-4	53.1mm	71.0mm	56	0.50	56.5mm	90	0.86	Wastegated

Dimension Note:

Compressor Inlet:

- PN 700382-3 - Page 47, Drawing 26
- PN 700382-20 - Page 47, Drawing 34
- PN 756021-1 - Page 47, Drawing 26
- PN 756021-2 - Page 47, Drawing 34

COMPRESSOR HOUSING OPTION

PN	Inlet Dia	Outlet Dia	A/R
756021-1*	2.75" Hose	2.00" Hose	0.50
756021-2**	4.00" Hose	2.00" Hose	0.50

- * Note: allows PN 700382-20 to use a 2.75" inlet instead of a 4.00"
- ** Note: allows PN 700382-3 to use a 4.00" inlet instead of a 2.75"

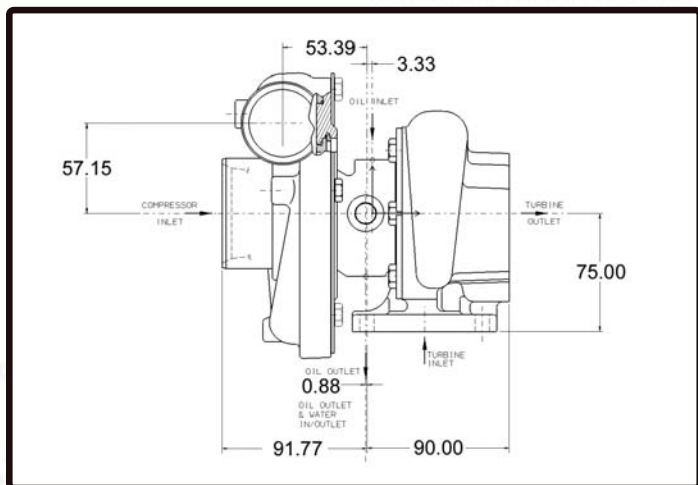
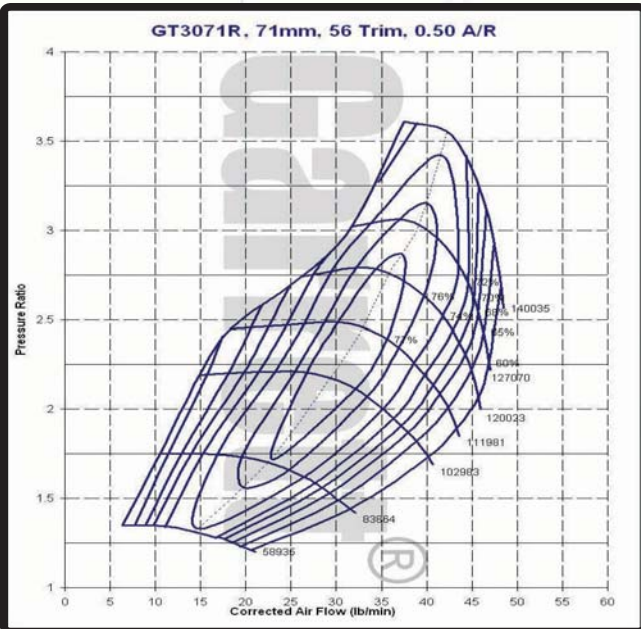

pursuit of power

Turbochargers > Medium Frame > GT30

GT3076R

Ball Bearing
Oil & Water-Cooled CHRA



APPLICATION

Horsepower 310 - 525
Displacement 2.0L - 3.5L

- Ball bearing CHRA & compressor housing; turbine housing kits sold separately
- Upgrade turbocharger for GT3071R non-wastegated dual ball bearing turbocharger; turbine housing flanges are outline interchangeable
- Turbine housing kit includes the turbine housing, clamps, bolts and turbine inlet gasket

FLANGE DIMENSIONS

Component	Inlet		Outlet	
	Page	Diagram	Page	Diagram
Compressor	47	35	47	17
Turbine	48	04	50	07
Oil	49	11	49	18
Water	51	12	51	12

GT3076R

COMPRESSOR

TURBINE

Turbo PN	CHRA PN	Ind Whl Dia	Exd Whl Dia	Trim	A/R	Whl Dia	Trim	A/R	Type
700382-12	700177-7	57.0mm	76.2mm	56	0.60	60.0mm	84	-	-

TURBINE HOUSING OPTION

PN	Whl Dia	Trim	A/R	Type
740902-1	-	-	1.06	Free Float
740902-2	-	-	0.82	Free Float
740902-3	-	-	0.63	Free Float

GT3076R, 76.2mm, 56 Trim, 0.60 A/R

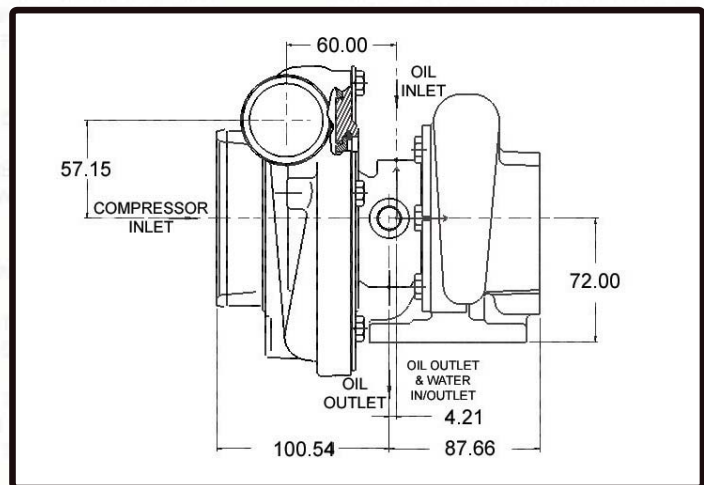
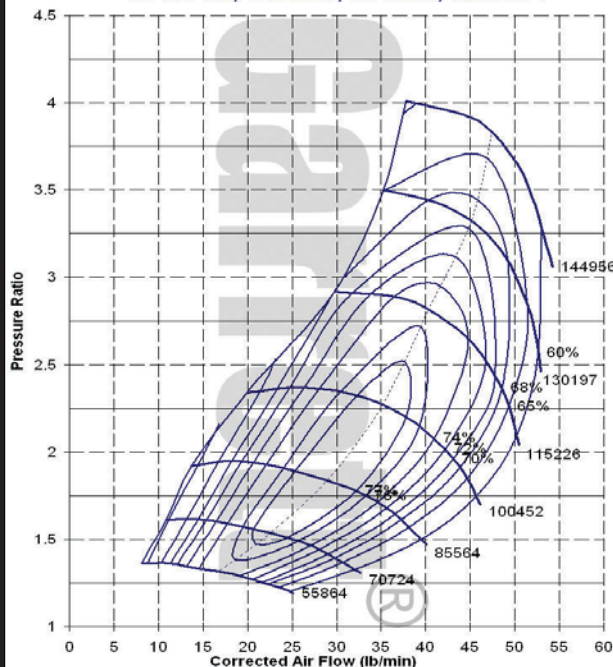

GT3271

Journal Bearing
Oil-Cooled CHRA

Garrett®



- Internally wastegated turbine housing, complete with actuator
- Wastegated and free float turbine housing options available
- **More GT32 turbocharger options available on page 54 and at www.TurboByGarrett.com**

APPLICATION

Horsepower 200 - 420
Displacement 2.0L - 3.0L

FLANGE DIMENSIONS

Component	Inlet		Outlet	
	Page	Diagram	Page	Diagram
Compressor	47	27	47	17
Turbine	49	01	51	01
Oil	49	13	49	08
Water	-	-	-	-

GT3271

COMPRESSOR

TURBINE

Turbo PN	CHRA PN	Ind Whl Dia	Exd Whl Dia	Trim	A/R	Whl Dia	Trim	A/R	Type
452203-1	436058-3	51.2mm	71.0mm	52	0.50	64.0mm	73	0.78	Wastegated

TURBINE HOUSING OPTION

PN	Whl Dia	Trim	A/R	Type
451225-26	-	-	0.78	Free Float
435066-32	-	-	0.69	Wastegated

GT3271, 71mm, 52 Trim, 0.50 A/R

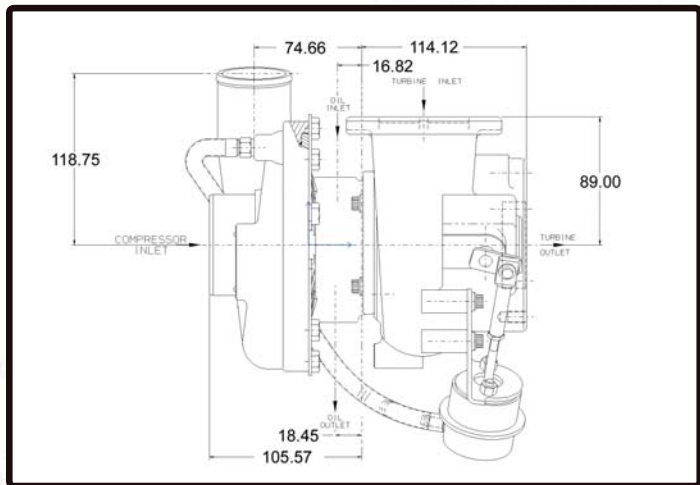
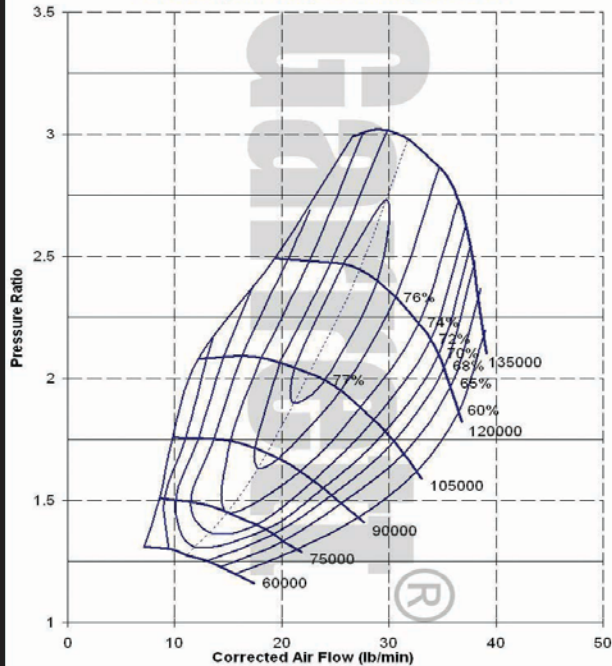

GT4082

Journal Bearing
Oil-Cooled CHRA

Garrett®

- Free float, non-wastegated turbine housing
- Divided turbine inlet



APPLICATION

Horsepower 370 - 575
Displacement 2.0L - 6.0L

FLANGE DIMENSIONS

Component	Inlet		Outlet	
	Page	Diagram	Page	Diagram
Compressor	47	31	47	08
Turbine	49	04	51	06
Oil	49	13	49	08
Water	-	-	-	-

GT4082

COMPRESSOR

TURBINE

Turbo PN	CHRA PN	Ind Whl Dia	Exd Whl Dia	Trim	A/R	Whl Dia	Trim	A/R	Type
452232-5	449739-10	58.0mm	82.0mm	50	0.58	77.0mm	73	0.94	Free Float

GT4082, 82mm, 50 Trim, 0.58 A/R

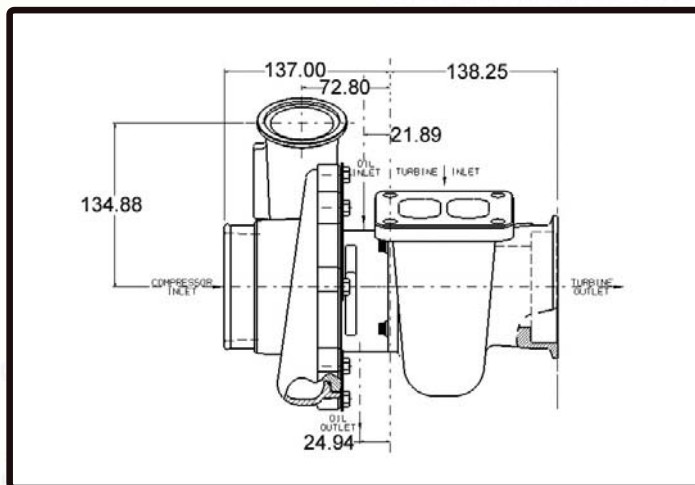
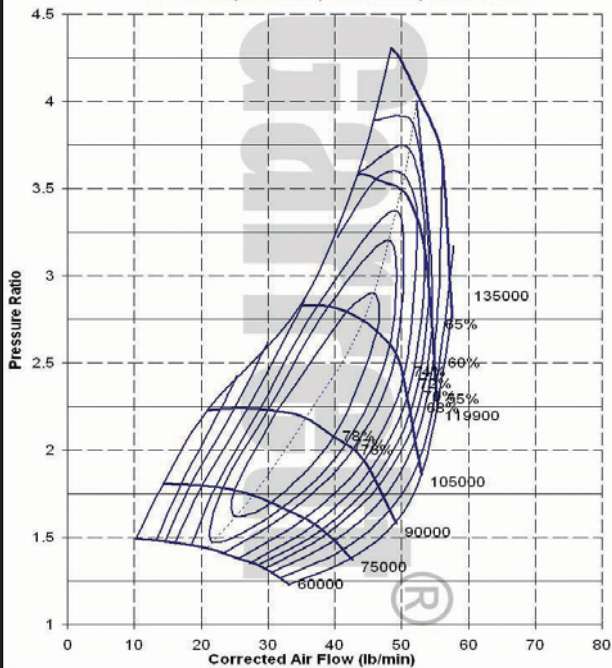

pursuit of power

Turbochargers > Large Frame > GT40

GT4088R

Ball Bearing
Oil & Water-Cooled CHRA



- Free float, non-wastegated turbine housing
- Journal bearing GT4088 options available on page 54 and www.TurboByGarrett.com

APPLICATION

Horsepower 400 - 700
Displacement 2.0L - 6.0L

FLANGE DIMENSIONS

Component	Inlet		Outlet	
	Page	Diagram	Page	Diagram
Compressor	47	31	47	25
Turbine	49	03	51	04
Oil	49	13	49	08
Water	51	13	51	13

GT4088R

COMPRESSOR

TURBINE

Turbo PN	CHRA PN	Ind Whl Dia	Exd Whl Dia	Trim	A/R	Whl Dia	Trim	A/R	Type
751470-1	751450-9	63.5mm	88.0mm	52	0.72	77.0mm	78	0.85	Free Float
751470-2	751450-9	63.5mm	88.0mm	52	0.72	77.0mm	78	0.95	Free Float
751470-3	751450-9	63.5mm	88.0mm	52	0.72	77.0mm	78	1.06	Free Float
751470-4	751450-9	63.5mm	88.0mm	52	0.72	77.0mm	78	1.19	Free Float

TURBINE HOUSING OPTION

PN	Whl Dia	Trim	A/R	Type
448375-18	-	-	0.85	Free Float
448375-19	-	-	0.95	Free Float
448375-20	-	-	1.06	Free Float
448375-21	-	-	1.19	Free Float

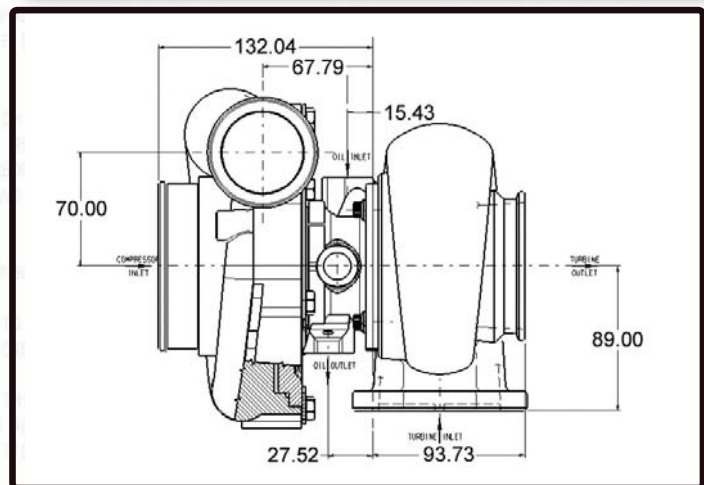
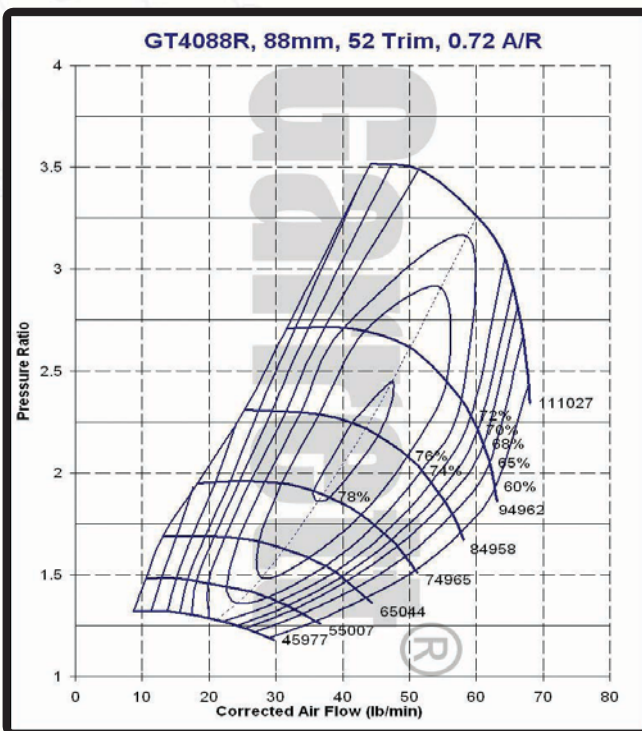

GT4094R

Ball Bearing
Oil & Water-Cooled CHRA

Garrett®



- Free float, non-wastegated turbine housing
- Ideal for applications that cannot fit the GT4294R but need more flow than the GT4088R
- Outline interchangeable with the GT4088R

APPLICATION

Horsepower 450 - 800
Displacement 2.0L - 5.7L

FLANGE DIMENSIONS

Component	Inlet		Outlet	
	Page	Diagram	Page	Diagram
Compressor	47	31	47	25
Turbine	49	03	51	04
Oil	49	13	49	08
Water	51	13	51	13

GT4094R

COMPRESSOR

TURBINE

Turbo PN	CHRA PN	Ind Whl Dia	Exd Whl Dia	Trim	A/R	Whl Dia	Trim	A/R	Type
751470-19	751450-16	67.8mm	94.0mm	52	0.72	77.0mm	78	0.85	Free Float
751470-20	751450-16	67.8mm	94.0mm	52	0.72	77.0mm	78	0.95	Free Float
751470-21	751450-16	67.8mm	94.0mm	52	0.72	77.0mm	78	1.06	Free Float
751470-22	751450-16	67.8mm	94.0mm	52	0.72	77.0mm	78	1.19	Free Float

TURBINE HOUSING OPTION

PN	Whl Dia	Trim	A/R	Type
448375-18	-	-	0.85	Free Float
448375-19	-	-	0.95	Free Float
448375-20	-	-	1.06	Free Float
448375-21	-	-	1.19	Free Float

GT4094R, 94mm, 52 Trim, 0.72 A/R

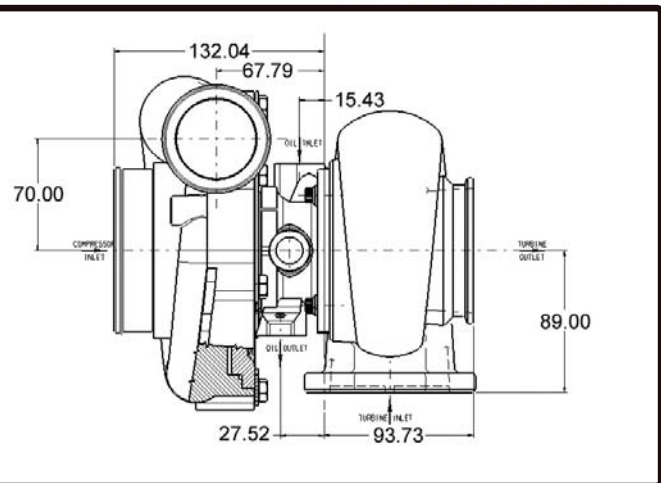
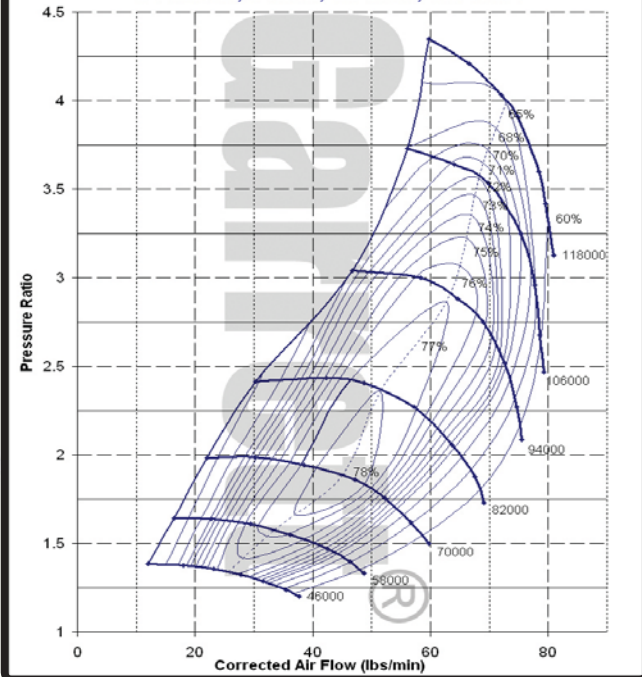

pursuit of power

Turbochargers > Large Frame > GT42

GT4294R

Ball Bearing
Oil & Water-Cooled CHRA



- Free float, non-wastegated turbine housing
- Housing kits include V-band clamps and necessary gaskets
- Perfect for high horsepower but responsive engines
- Ported shroud compressor housing to reduce the occurrence of surge
- Outline interchangeable with the journal bearing GT4294 CHRA (except for the requirement of water-cooling)
- **Journal bearing GT4294 options available on page 55 and www.TurboByGarrett.com**

APPLICATION

Horsepower 500 - 850
Displacement 2.0L - 8.0L

FLANGE DIMENSIONS

Component	Inlet		Outlet	
	Page	Diagram	Page	Diagram
Compressor	47	37	47	07
Turbine	49	03	51	06
Oil	49	17	49	08
Water	51	13	51	13

GT4294R

COMPRESSOR

TURBINE

Turbo PN	CHRA PN	Ind Whl Dia	Exd Whl Dia	Trim	A/R	Whl Dia	Trim	A/R	Type
774595-1	451888-9	70.3mm	94.0mm	56	0.60	82.0mm	84	1.01	Free Float
774595-2	451888-9	70.3mm	94.0mm	56	0.60	82.0mm	84	1.15	Free Float
774595-3	451888-9	70.3mm	94.0mm	56	0.60	82.0mm	84	1.28	Free Float
774595-4	451888-9	70.3mm	94.0mm	56	0.60	82.0mm	84	1.44	Free Float

TURBINE HOUSING OPTION

PN	Whl Dia	Trim	A/R	Type
757707-10*	-	-	1.01	Free Float
757707-9*	-	-	1.15	Free Float

Dimension Note:
*757707-9 & -10 feature a large diesel inlet flange: Page 49, Drawing 05;
outlet flange Page 51, Drawing 05

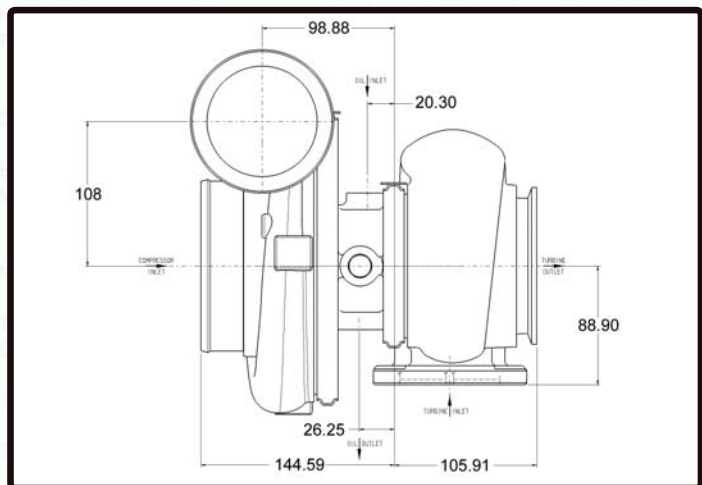
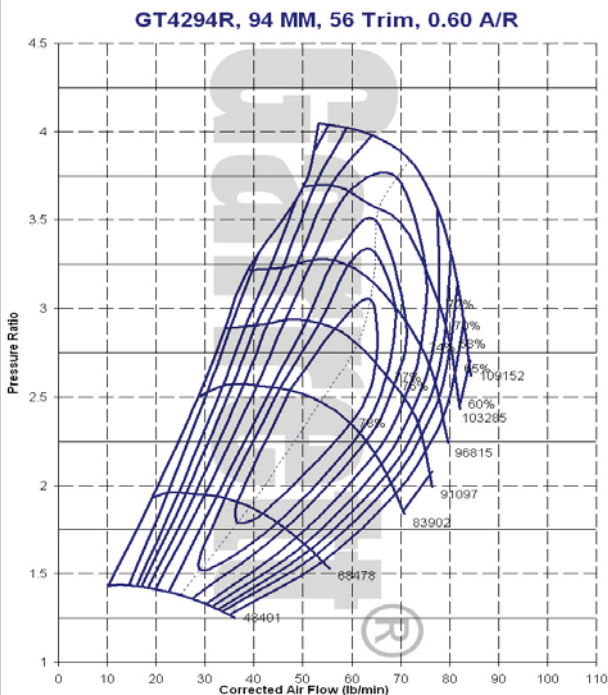

GT4202R

Ball Bearing
Oil & Water-Cooled CHRA



- Free float, non-wastegated turbine housings available
- Housing kits include V-band clamps and necessary gaskets
- Compressor housing kit includes compressor wheel, compressor housing, backplate and all necessary hardware
- Ported shroud compressor housing to reduce the occurrence of surge
- Outline interchangeable with the journal bearing GT4202 CHRA (except for the requirement of water-cooling)
- **Journal bearing GT4202 options available on page 55 and at www.TurboByGarrett.com**

APPLICATION

Horsepower 700 - 1000
Displacement 2.0L - 8.0L

FLANGE DIMENSIONS

Component	Inlet		Outlet	
	Page	Diagram	Page	Diagram
Compressor	47	37	47	07
Turbine	49	03	51	06
Oil	49	17	49	08
Water	51	13	51	13

GT4202R

COMPRESSOR

TURBINE

Turbo PN	CHRA PN	Ind Whl Dia	Exd Whl Dia	Trim	A/R	Whl Dia	Trim	A/R	Type
774595-5	451888-11	74.7mm	102.3mm	53	0.60	82.0mm	84	1.01	Free Float
774595-6	451888-11	74.7mm	102.3mm	53	0.60	82.0mm	84	1.15	Free Float
774595-7	451888-11	74.7mm	102.3mm	53	0.60	82.0mm	84	1.28	Free Float
774595-8	451888-12	74.7mm	102.3mm	53	0.60	82.0mm	84	1.44	Free Float

GT4202R, 102mm, 53 Trim, 0.60 A/R

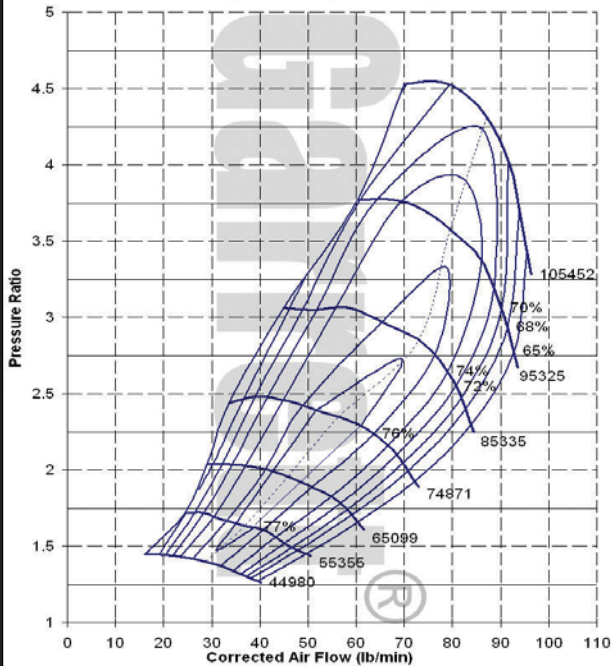

TURBINE HOUSING OPTION

PN	Whl Dia	Trim	A/R	Type
757707-10**	-	-	1.01	Free Float
757707-9**	-	-	1.15	Free Float

Dimension Note:

**757707-9 & -10 feature a large diesel inlet flange: Page 49, Drawing 05; outlet flange Page 51, Drawing 05

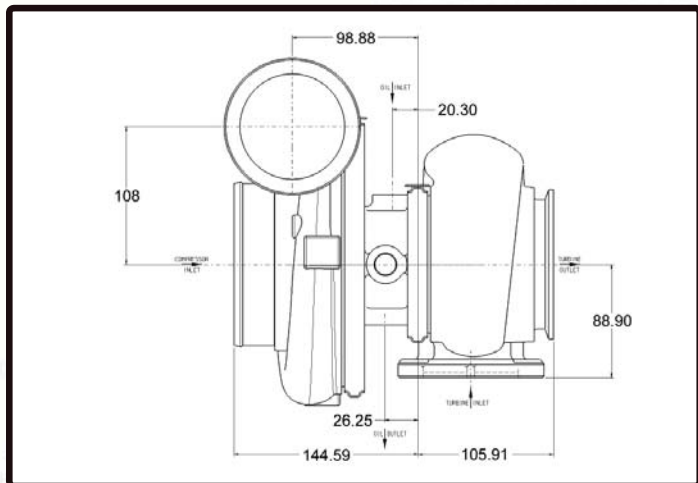

pursuit of power

Turbochargers > Large Frame > GT45

GT4508R

Ball Bearing
Oil & Water-Cooled CHRA



- Free float, non-wastegated turbine housing
- Perfect for high horsepower yet responsive engines

APPLICATION

Horsepower 700 - 1100
Displacement 2.0L - 8.0L

FLANGE DIMENSIONS

Component	Inlet		Outlet	
	Page	Diagram	Page	Diagram
Compressor	47	38	47	07
Turbine	49	03	51	06
Oil	49	17	49	08
Water	51	13	51	13

GT4508R

COMPRESSOR

TURBINE

Turbo PN	CHRA PN	Ind Whl Dia	Exd Whl Dia	Trim	A/R	Whl Dia	Trim	A/R	Type
774596-1	451888-28	80.8mm	108.0mm	56	0.69	87.0mm	85	1.01	Free Float
774596-2	451888-28	80.8mm	108.0mm	56	0.69	87.0mm	85	1.15	Free Float
774596-3	451888-28	80.8mm	108.0mm	56	0.69	87.0mm	85	1.28	Free Float
774596-4	451888-28	80.8mm	108.0mm	56	0.69	87.0mm	85	1.44	Free Float

TURBINE HOUSING OPTION

PN	Whl Dia	Trim	A/R	Type
757707-5	-	-	1.01	Free Float
757707-6	-	-	1.15	Free Float
757707-7	-	-	1.28	Free Float
757707-8	-	-	1.44	Free Float

GT4508R, 108mm, 56 Trim, 0.69 A/R

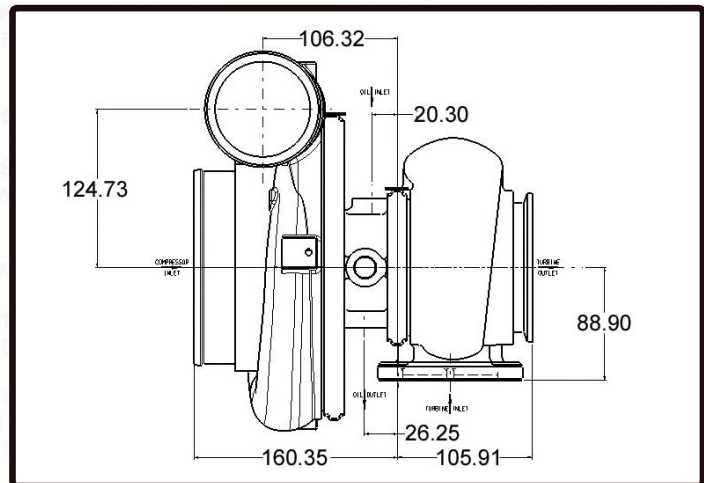
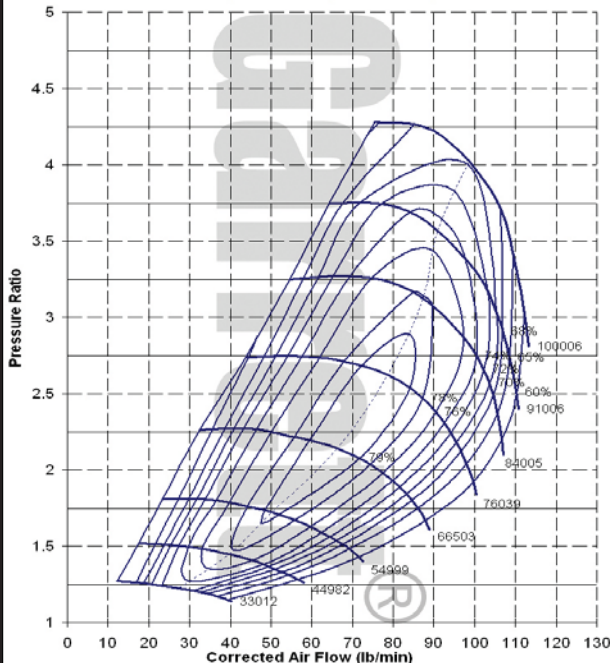

GT4708R

Ball Bearing
Oil-Cooled CHRA



- Free float, non-wastegated turbine housing
- Journal bearing GT4708 options available on page 55 and at www.TurboByGarrett.com



APPLICATION

Horsepower 700 - 1200
Displacement 2.5L - 10.0L

FLANGE DIMENSIONS

Component	Inlet		Outlet	
	Page	Diagram	Page	Diagram
Compressor	47	38	47	30
Turbine	48	05	51	10
Oil	49	12	49	08
Water	-	-	-	-

GT4708R

COMPRESSOR

TURBINE

Turbo PN	CHRA PN	Ind Whl Dia	Exd Whl Dia	Trim	A/R	Whl Dia	Trim	A/R	Type
769112-1	769210-1	80.7mm	108.0mm	56	0.69	92.7mm	82	0.96	Free Float
769112-2	769210-1	80.7mm	108.0mm	56	0.69	92.7mm	82	1.08	Free Float
769112-3	769210-1	80.7mm	108.0mm	56	0.69	92.7mm	82	1.23	Free Float
769112-4	769210-1	80.7mm	108.0mm	56	0.69	92.7mm	82	1.39	Free Float

TURBINE HOUSING OPTION

PN	Whl Dia	Trim	A/R	Type
761208-9	-	-	0.96	Free Float
761208-10	-	-	1.08	Free Float
761208-11	-	-	1.23	Free Float
761208-12	-	-	1.39	Free Float

GT4708R, 108mm, 56 Trim, 0.69 A/R

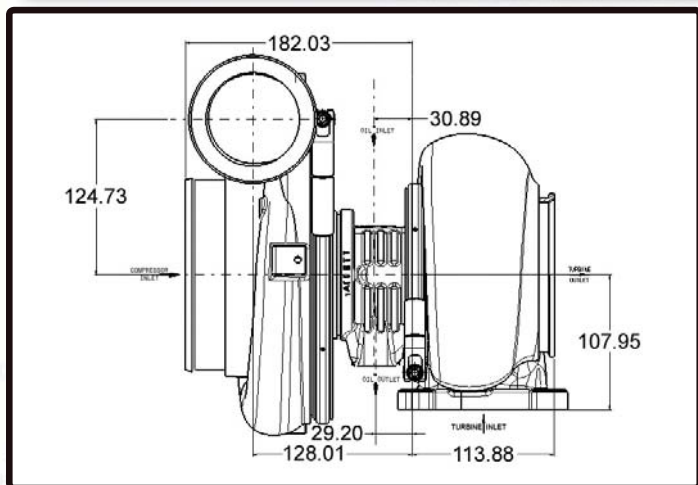
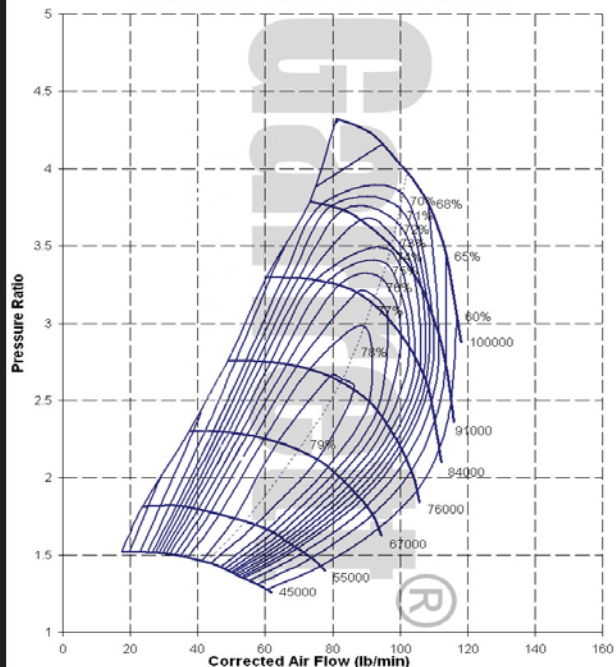

pursuit of power

Turbochargers > Large Frame > GT47

GT4718R

Ball Bearing
Oil-Cooled CHRA



- Free float, non-wastegated turbine housing
- Journal bearing GT4718 options available on page 55 and at www.TurboByGarrett.com

APPLICATION

Horsepower 850 - 1400
Displacement 2.5L - 10.0L

FLANGE DIMENSIONS

Component	Inlet		Outlet	
	Page	Diagram	Page	Diagram
Compressor	47	38	47	30
Turbine	48	05	51	10
Oil	49	12	49	08
Water	-	-	-	-

GT4718R

COMPRESSOR

TURBINE

Turbo PN	CHRA PN	Ind Whl Dia	Exd Whl Dia	Trim	A/R	Whl Dia	Trim	A/R	Type
769112-5	769210-2	88.0mm	117.6mm	56	0.69	92.7mm	82	0.96	Free Float
769112-6	769210-2	88.0mm	117.6mm	56	0.69	92.7mm	82	1.08	Free Float
769112-7	769210-2	88.0mm	117.6mm	56	0.69	92.7mm	82	1.23	Free Float
769112-8	769210-2	88.0mm	117.6mm	56	0.69	92.7mm	82	1.39	Free Float

TURBINE HOUSING OPTION

PN	Whl Dia	Trim	A/R	Type
761208-9	-	-	0.96	Free Float
761208-10	-	-	1.08	Free Float
761208-11	-	-	1.23	Free Float
761208-12	-	-	1.39	Free Float

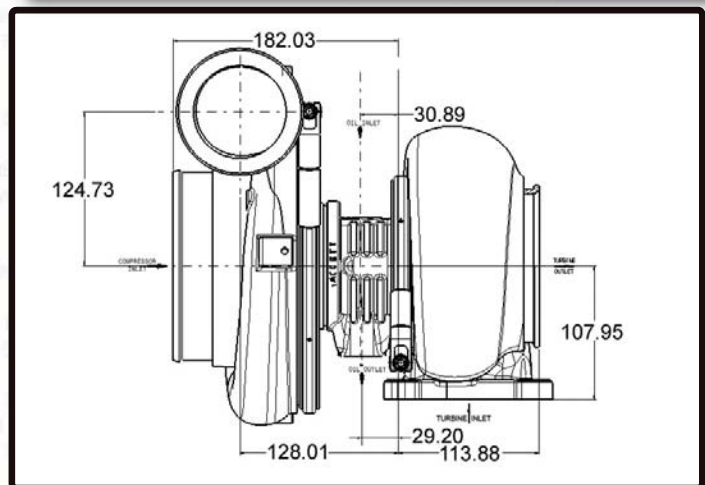
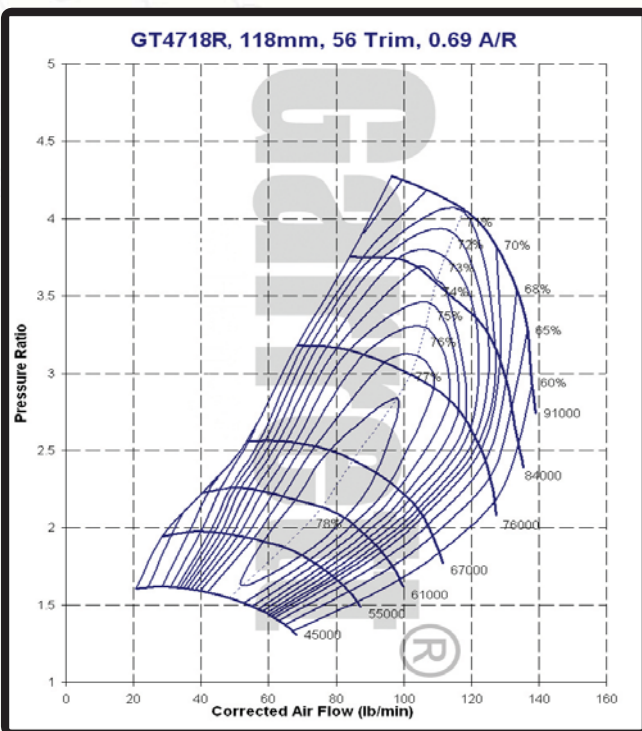

GT5533R

Ball Bearing
Oil-Cooled CHRA

Garrett®



- Free Float, non-wastegated turbine housing
- The GT5533R (PN 769115-1) is a fully customizable Garrett® ball bearing GT turbo that is packaged without the turbine housing. It includes a CHRA and compressor housing
- Largest Garrett ball bearing turbocharger available
- Turbine wheel is cast from “Inconel” material for extreme applications
- Journal bearing GT5533 options available on page 55 and at www.TurboByGarrett.com

APPLICATION

Horsepower 1000 - 1550
Displacement 3.0L - 12.0L

FLANGE DIMENSIONS

Component	Inlet		Outlet	
	Page	Diagram	Page	Diagram
Compressor	47	38	47	30
Turbine	48	05	51	10
Oil	49	12	49	08
Water	-	-	-	-

GT5533R

COMPRESSOR

TURBINE

Turbo PN	CHRA PN	Ind Whl Dia	Exd Whl Dia	Trim	A/R	Whl Dia	Trim	A/R	Type
769115-1	769210-3	91.2mm	133.0mm	47	0.69	111.4mm	84	-	-

TURBINE HOUSING OPTION

PN	Whl Dia	Trim	A/R	Type
761208-13	-	-	0.90	Free Float
761208-14	-	-	1.00	Free Float
761208-15	-	-	1.12	Free Float
761208-16	-	-	1.24	Free Float
761208-17	-	-	1.40	Free Float

GT5533R,133mm,47 Trim,0.69 A/R

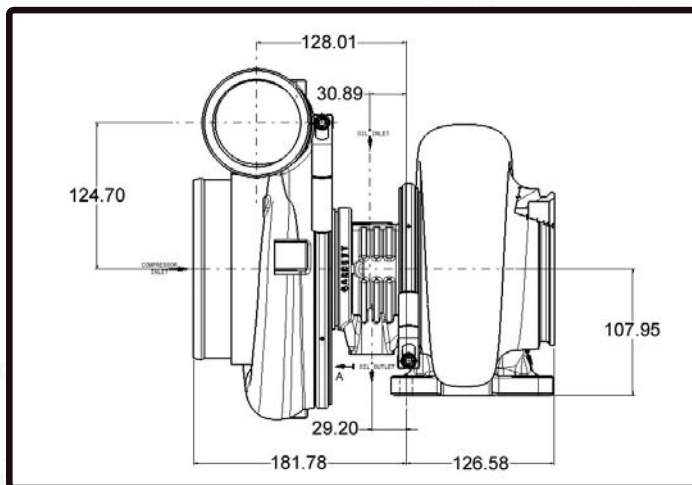
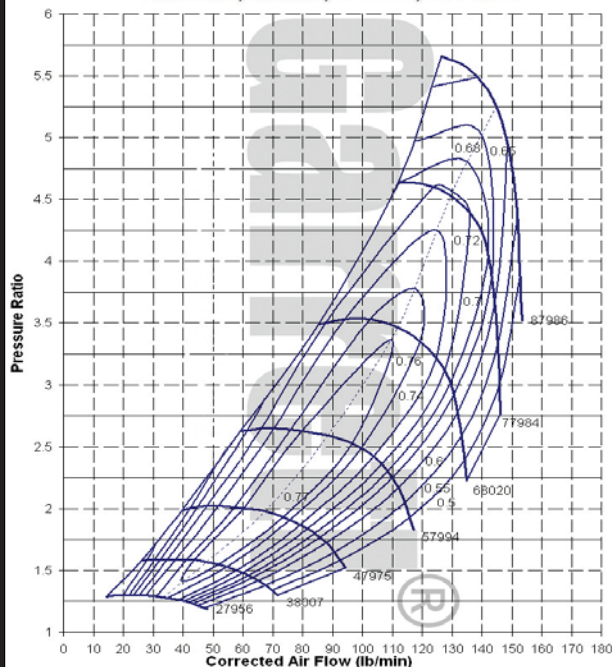

pursuit of power

Turbochargers > Large Frame > GT60

GT6041
Journal Bearing
Oil-Cooled CHRA



- Free float, non-wastegated turbine housing
- Turbine wheel cast from "Inconel" material for extreme applications
- Largest Garrett® turbocharger available

APPLICATION

Horsepower 1450 - 2000
Displacement 6.0L - 12.0L

FLANGE DIMENSIONS

Component	Inlet		Outlet	
	Page	Diagram	Page	Diagram
Compressor	47	38	47	03
Turbine	48	05	51	09
Oil	49	14	49	09
Water	-	-	-	-

GT6041

COMPRESSOR

TURBINE

Turbo PN	CHRA PN	Ind Whl Dia	Exd Whl Dia	Trim	A/R	Whl Dia	Trim	A/R	Type
731377-1	730496-1	105.7mm	141.0mm	56	1.05	130.0mm	84	1.47	Free Float

TURBINE HOUSING OPTION

PN	Whl Dia	Trim	A/R	Type
441319-97	-	-	1.25	Free Float

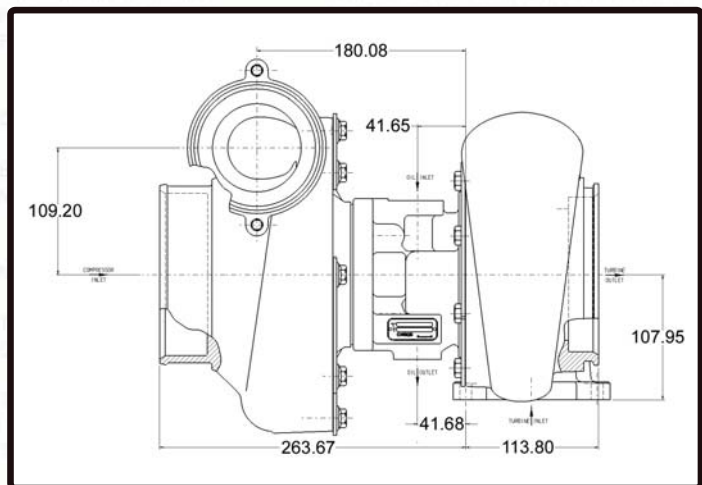
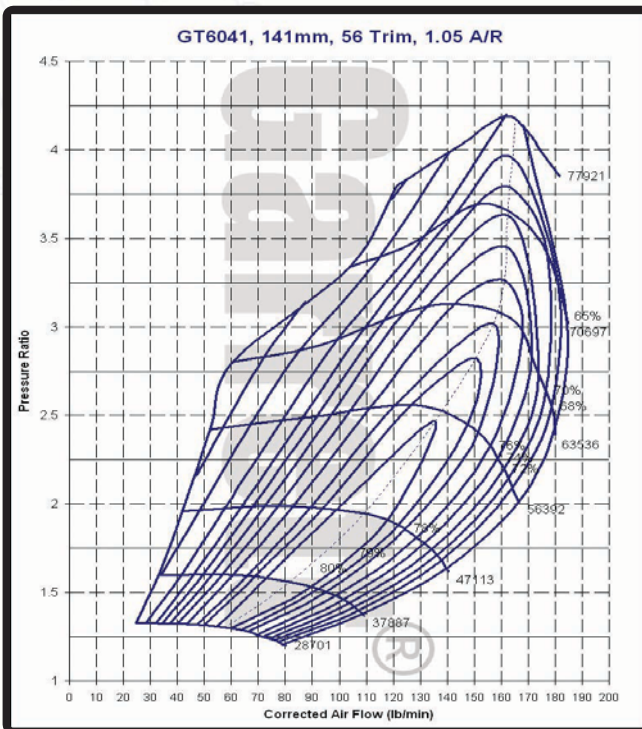

Ball Bearing T-Series

Ball Bearing
Oil & Water-Cooled CHRA

Garrett®



APPLICATION

T3/T4, T04
(any manufacturer)

T-Series Ball Bearing Replacements

Garrett®, having created the original T3/T4 turbocharger, has introduced center housing upgrades for many existing T-Series turbochargers. Now you can keep your current turbo setup as well as your compressor and turbine housings while gaining the peace of mind that comes with every patented Garrett® dual ball bearing unit.

- Ball bearing CHRA upgrade
- Reduced spool-up time, reduced lag
- Direct drop-in replacement for T3/T4 turbochargers
- Keep your current compressor and turbine housings
- Keep your current intercooler, piping and downpipe

T Series			COMPRESSOR		TURBINE	
Turbo	CHRA (Ball Bearing)	Upgrade for CHRA	Exd Whl Dia	Trim	Whl Dia	Trim
T04B	757197-1	408105-0388	76.0mm	60	74.2mm	76
T04Z	740759-2	-	84.0mm	63	74.2mm	76
T3/T4R	757197-2	445074-0032	75.0mm	57	65.0mm	76
T3/T4R	757197-3	445074-0033	75.0mm	60	65.0mm	76
T3/T4R	757197-4	447450-0059	76.0mm	50	65.0mm	76
T3/T4R	757197-5	715582-0002	76.0mm	60	65.0mm	76
T350R	757197-7	-	76.0mm	60	71.0mm	76

- **Quality** - Using the same OE-based testing that is used for the world renowned GT series of turbos, the T3/T4, T04B and T04Z center housing upgrades are rigorously beaten to ensure that they can wear the Garrett® badge.
- **Dependability** - The center housing is a true Garrett® dual ball bearing cartridge. This means reduced turbo spool up time and greater pressure handling while using less oil. This all equals a better driving experience.
- **Easy Installation** - All those hours you put into planning, installing, tuning and honing your turbo setup won't have to be doubled with a completely new turbo. In fact, the installation is as easy as removing your old journal or

hybrid-bearing center housing and replacing it with a true Garrett® dual ball bearing cartridge. Place your current compressor and turbine housings on, put it back into your engine bay and hook up the water line (oil lines may differ).

You may use your housings even if you have another manufacturer's turbo!

- **Proven Reliability** - With thousands of passes in the professional drag race books, Garrett® turbos have built a reputation as the one turbo that lasts. One NHRA Sport Compact professional racer, using a competitor's product, went through 16 units in one season. He's now switched to Garrett® and is confident that the patented dual ball bearing cartridge can be counted on for every pass.

See an authorized Garrett® Distributor for T-Series turbos and ancillary parts

pursuit of power

Turbocharger Kits > Diesel > PowerMax™

Chevy Duramax

2001 - 2004
Chevy Silverado, GMC Sierra & LB7



APPLICATION

**Chevrolet & GMC Duramax
Silverado, Sierra & LB7**

This is a complete drop-in performance upgrade turbocharger kit that provides extra flow, efficiency and durability, delivering the boost you need.

- Advanced GT-series wheel designs that ensure top performance, lower back pressure and reduced intake and exhaust gas temperatures.
- Patented Garrett® dual ball-bearing cartridge that offers unbeatable low drag response and the durability required at elevated boost levels.
- Capable of an additional 370+ HP increase over stock
- Part Number 766172-1

Performance	0-60 MPH	Horsepower	Torque
Stock	7.6 seconds	279	560
PowerMax*	6.8 seconds	440	808

* with performance chip and exhaust

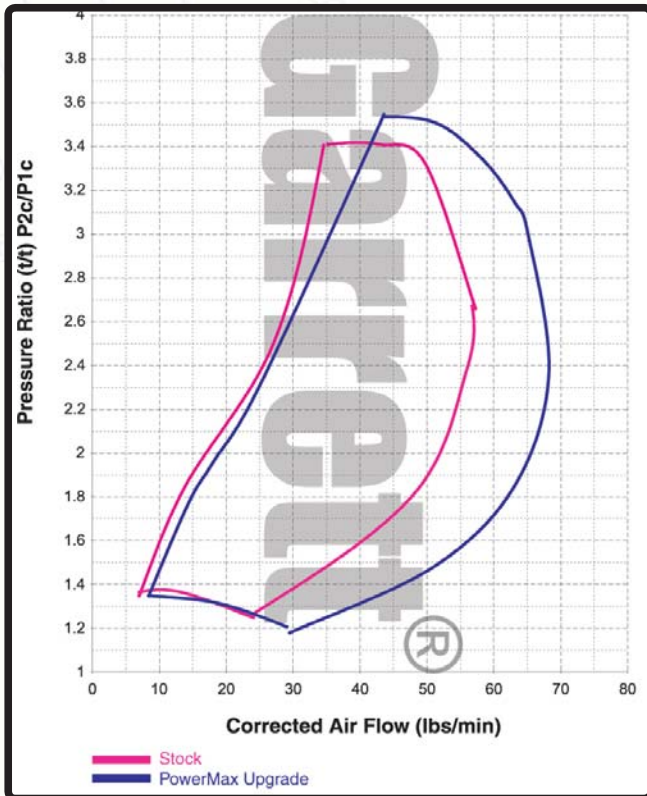

The PowerMax™ Duramax Turbo Kit includes:

- Garrett® GT3788R Turbocharger
- Turbine inlet adapter
- High flow downpipe
- Oil inlet fitting with restrictor
- Gaskets, O-rings and fasteners
- Installation instructions

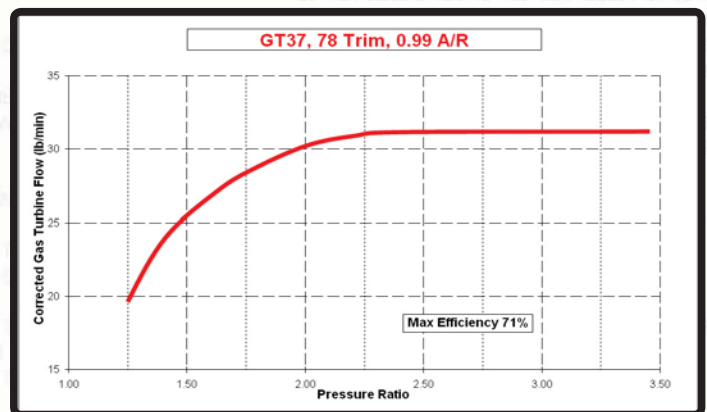

Dodge Ram

1998.5 - 2002
5.9L 2500 & 3500

Garrett®



APPLICATION

Dodge Ram - 5.9L
2500 & 3500 Cummins

This turbo kit features the exclusive Garrett® dual ball bearing cartridge, GT wheel aerodynamics and a water-cooled center housing

- **Stage 1** - GT3782R (PN 759361-1)
 - Featuring an 82mm, 56 trim compressor wheel that can produce an increase of 170+HP over stock
- **Stage 2** - GT3782R (PN 759361-2)
 - Featuring a higher flowing 82mm, 56 trim compressor wheel that can produce an increase of 270+HP over stock
- **Stage 3** - GT3788R (PN 759361-3)
 - Featuring a super high-flowing 88mm, 52 trim compressor wheel that can produce an additional 370+HP over stock

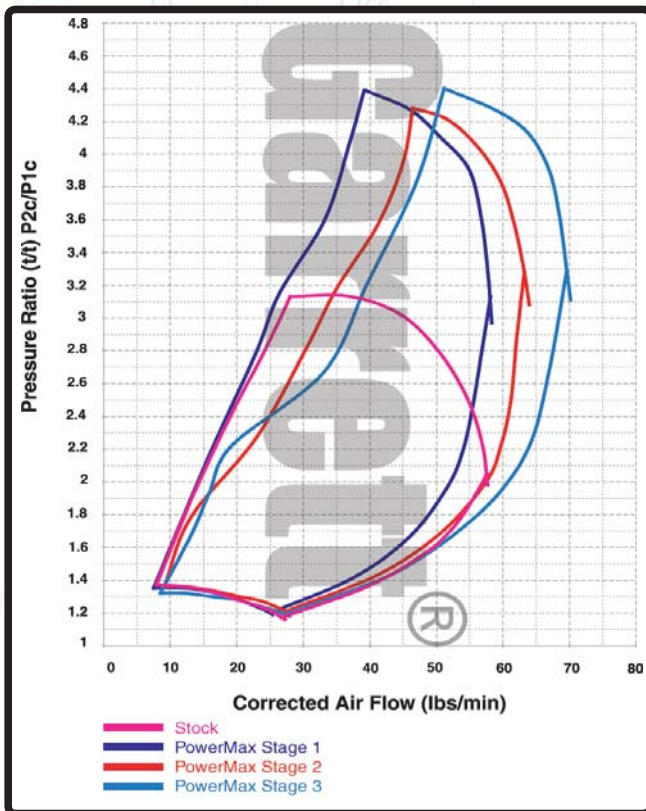

The PowerMax™ Cummins Turbo Kit includes:

- Stage 1, 2 or 3 Turbocharger
- Oil inlet fitting kit with restrictor
- Water line kit
- Turbine inlet bolts
- Gasket kit
- Turbine outlet adapter kit
- Compressor housing clamp
- Installation instructions

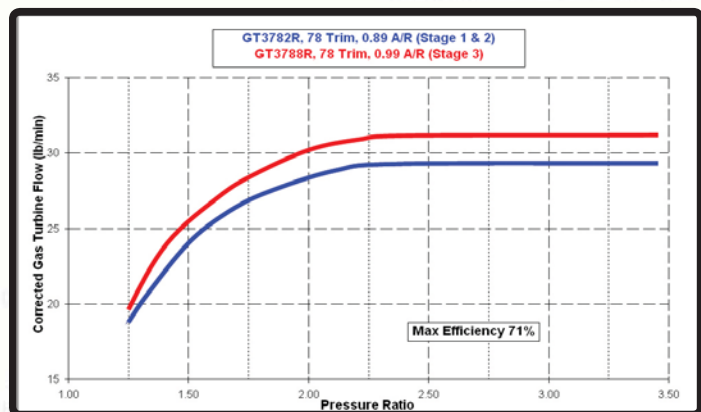

pursuit of power

Turbocharger Kits > Diesel Kits > PowerMax™

Dodge Ram

2002.5 - 2006
5.9L 2500 & 3500



APPLICATION

**Dodge Ram - 5.9L
2500 & 3500 Cummins**

Advanced GT-series wheel designs ensure top performance, lower back pressure and reduced intake and exhaust gas temperatures.

- **Stage 1 - GT3782R**
 - 2002.5 - 2004 (PN 759361-4)
 - 2004.5 - 2006 (PN 759361-7)
 - Featuring an 82mm compressor wheel (with 50 trim); increased surge margin; ideal for towing. Provides the best boost response of the three stages, but with the least headroom
- **Stage 2 - GT3782R**
 - 2002.5 - 2004 (PN 759361-5)
 - 2004.5 - 2006 (PN 759361-8)
 - Featuring an 82mm compressor wheel (with 56 trim); provides increased compressor flow capability over Stage 1
- **Stage 3 - GT3788R**
 - 2002.5 - 2004 (PN 759361-6)
 - 2004.5 - 2006 (PN 759361-9)
 - Featuring an 88mm compressor wheel (with 52 trim); larger turbine housing A/R, increased turbine flow and compressor wheel size and flow over Stage 1 and 2. Highest horsepower potential of the three stages

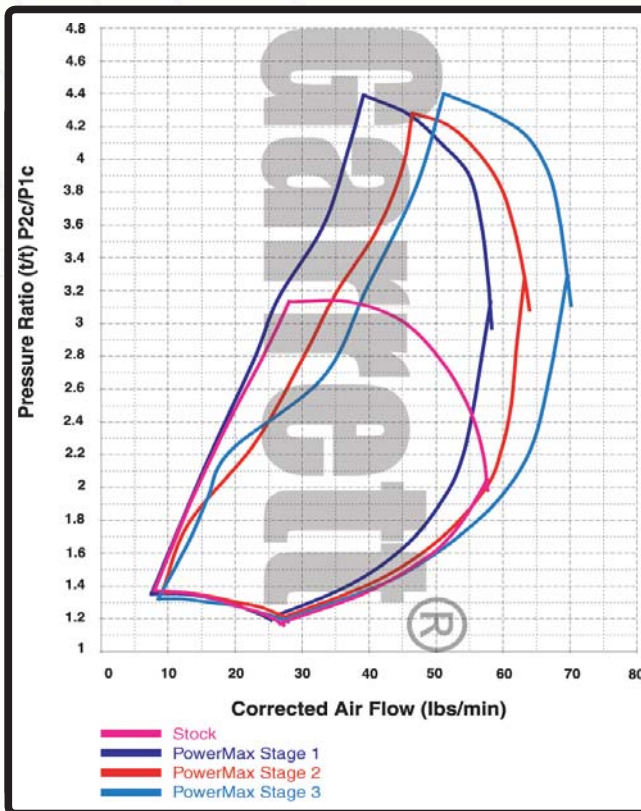

The PowerMax™ Cummins Turbo Kit includes:

- Stage 1, 2 or 3 Turbocharger
- Oil inlet fitting kit with restrictor
- Water line kit
- Turbine inlet bolts
- Gasket kit
- Turbine outlet adapter kit
- Compressor housing clamp
- Installation instructions

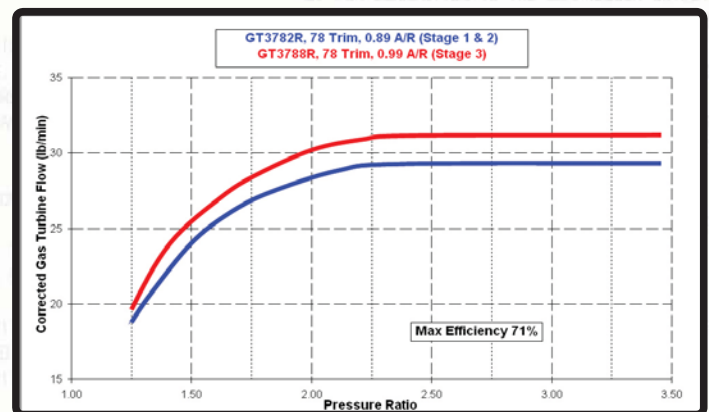

Ford Powerstroke

1999.5 - 2003
7.3L Excursion & F-Series

Garrett®



APPLICATION

Ford Powerstroke - 7.3L
Excursion & F-Series

With this turbo kit, you will experience Garrett® GT dual ball bearing technology working to give you unbelievable power pushing your truck to the limits

- A patented Garrett® dual ball bearing cartridge for unbeatable response, efficiency and durability. Elimination of the thrust bearing eliminates failures at elevated boost levels
- The 88mm GT compressor wheel provides 33% more flow than the stock 80mm wheel. Ported shroud housing improves compressor flow range for surge control and increased choke flow
- 1.00 A/R turbine housing for free flowing exhaust with reduced back pressure and up to 200° reduction in exhaust gas temperature
- Maximum recommended boost level is 40 psig
- Part Number 739619-4

Performance	0-60 MPH	Horsepower	Torque
Stock	11.0 seconds	208	410
PowerMax	7.9 seconds	280	550

* with performance chip and exhaust

The PowerMax™ Ford Powerstroke Turbo Kit includes:

- GTP38R Turbocharger
- 4-inch inlet hose
- Band clamp
- Oil seal rings
- Installation instructions

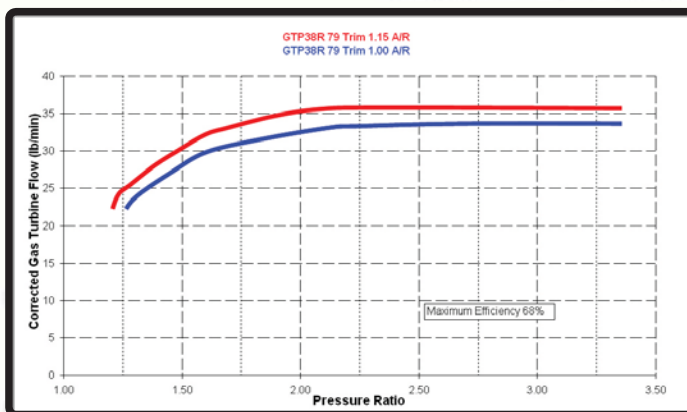
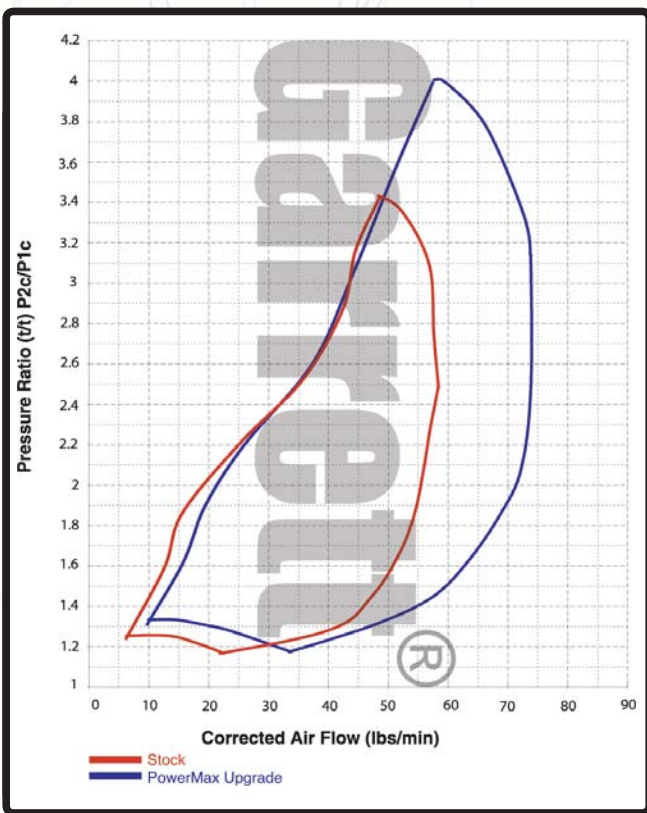

pursuit of power

Turbochargers > Sizes & Dimensions
Sizes & Dimensions
 Compressor Inlet & Outlet Flanges
 Sizes & Dimensions

01

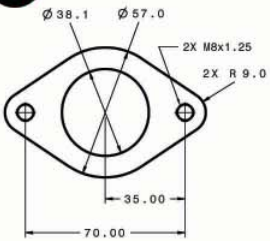

02

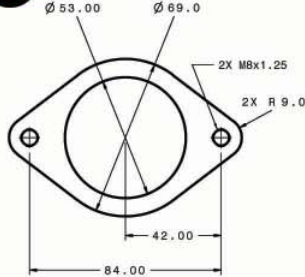

03

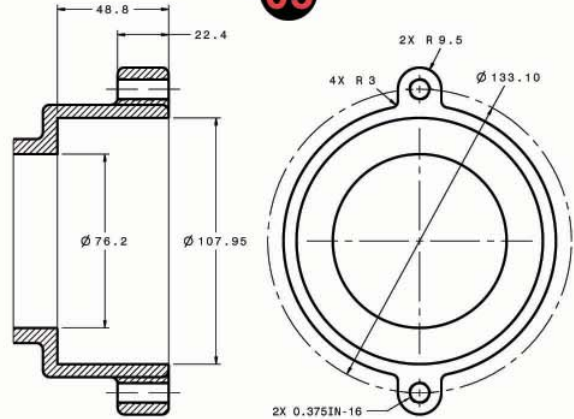

04

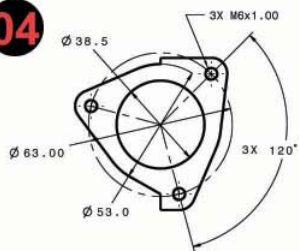

05

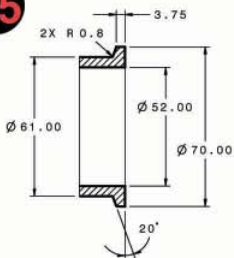

06

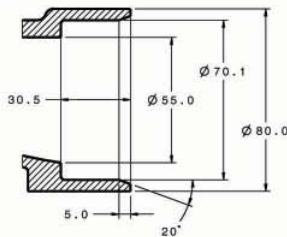

07

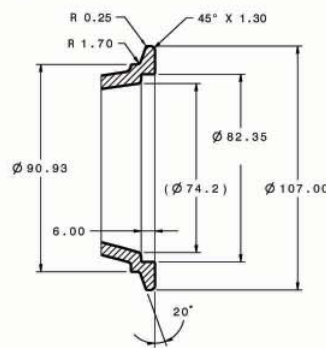

08

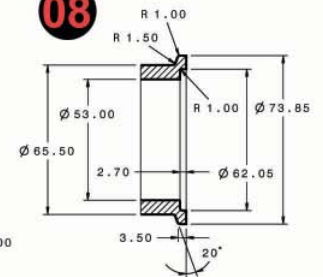

Hose Connections

09 $\varnothing 36 \times 20$	20 $\varnothing 54 \times 25$	30 $\varnothing 88.9 \times 32$
10 $\varnothing 36 \times 25$	21 $\varnothing 60 \times 25$	31 $\varnothing 101.6 \times 25.0$
11 $\varnothing 36 \times 26$	22 $\varnothing 60 \times 30$	32 $\varnothing 101.6 \times 25.4$
12 $\varnothing 45.9 \times 23.25$	23 $\varnothing 60 \times 32$	33 $\varnothing 101.6 \times 31.75$
13 $\varnothing 46 \times 21$	24 $\varnothing 63.5 \times 30$	34 $\varnothing 102 \times 31.75$
14 $\varnothing 46 \times 23.3$	25 $\varnothing 65 \times 32$	35 $\varnothing 103.6 \times 31.75$
15 $\varnothing 50 \times 25$	26 $\varnothing 69.85 \times 31.75$	36 $\varnothing 106 \times 32$
16 $\varnothing 50 \times 35$	27 $\varnothing 70 \times 31.75$	37 $\varnothing 127 \times 32$
17 $\varnothing 50.8 \times 30$	28 $\varnothing 76.2 \times 31.75$	38 $\varnothing 152.4 \times 32$
18 $\varnothing 51 \times 25$	29 $\varnothing 78.2 \times 28.6$	39 $\varnothing 152.4 \times 35$
19 $\varnothing 51 \times 30$		

HOSE CONNECTIONS
 TABULATED AS ($\varnothing \times L$)

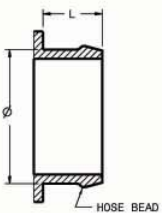

All Dimension Measurements in Millimeters (mm)

Sizes & Dimensions

Turbine Housing Inlet Flanges
Sizes & Dimensions

Garrett®

01 "T25"

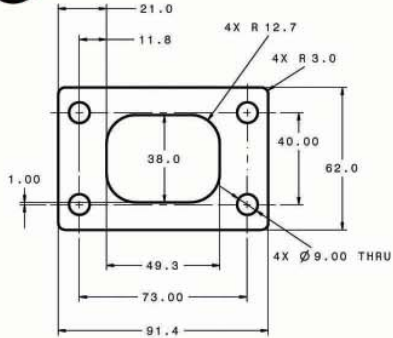

02 "T25 WITH STUDS"

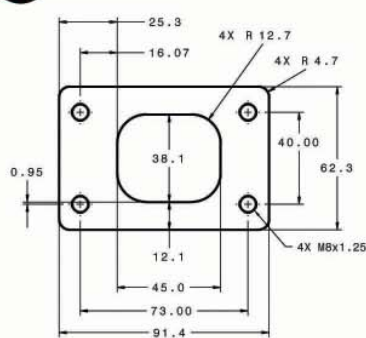

03 "T25 WITH STUDS"

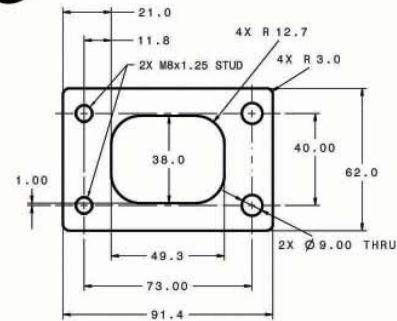

04 "T3"

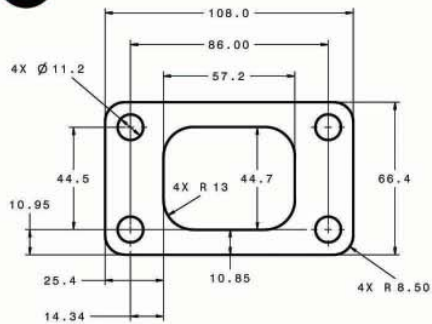

05 "LARGE FRAME DIESEL"

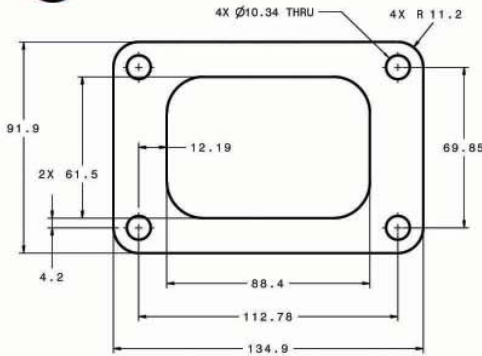

06

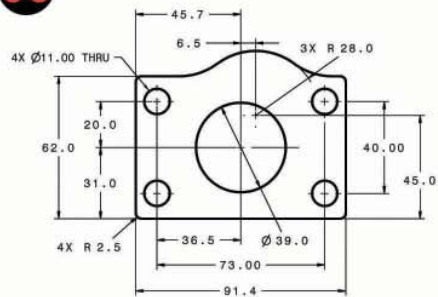

07

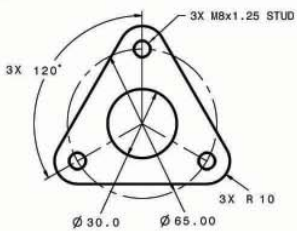

08

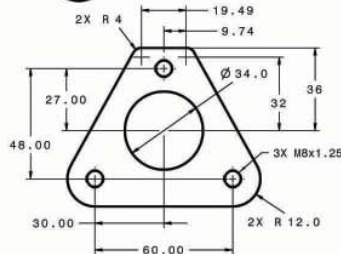

09

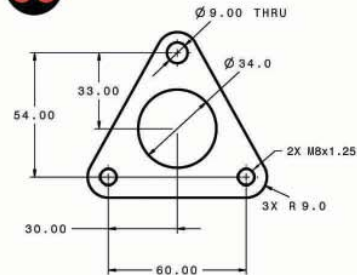

All Dimension Measurements in Millimeters (mm)

pursuit of power

Turbochargers > Sizes & Dimensions
Sizes & Dimensions
 Turbine Housing Inlet Flanges & Oil Lines
 Sizes & Dimensions

01 "T3 DIVIDED"

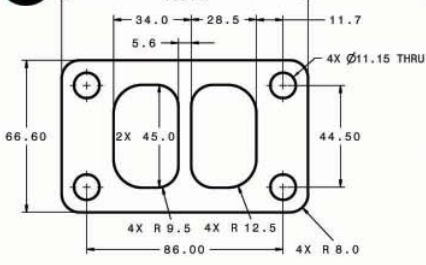

02 "T4"

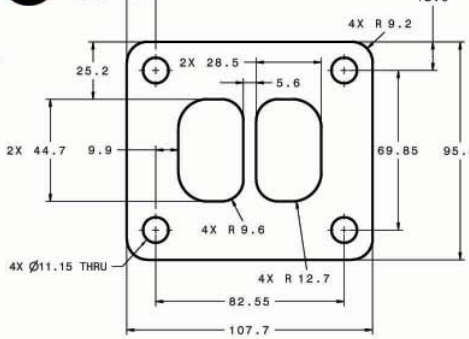

03 "T4 DIVIDED"

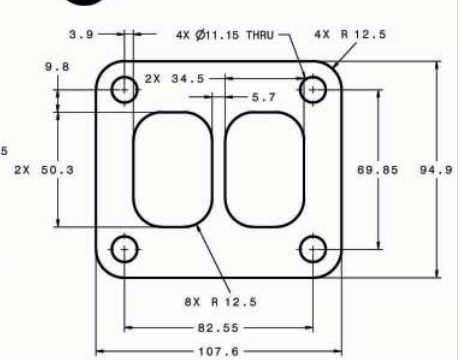

04 "T4I"

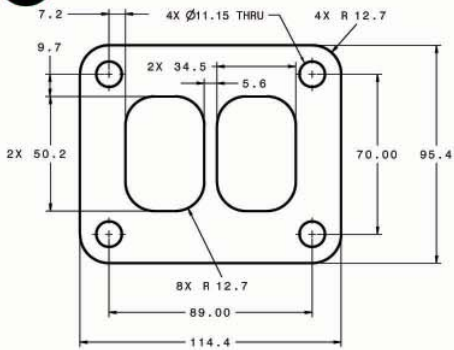

05 "LARGE FRAME DIESEL DIVIDED"

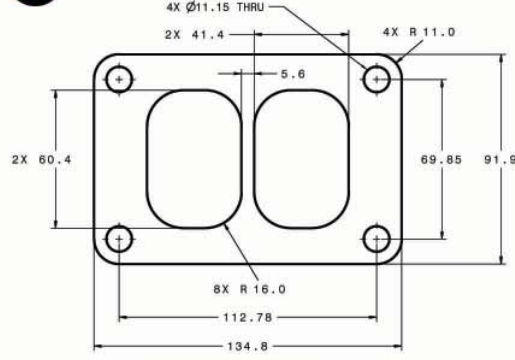

06

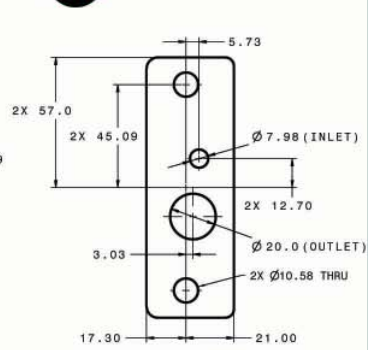

07

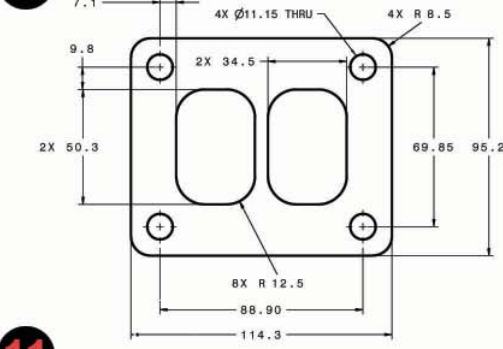

08

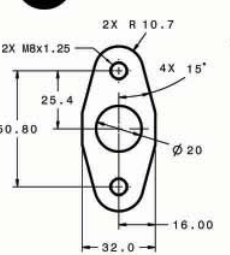

09

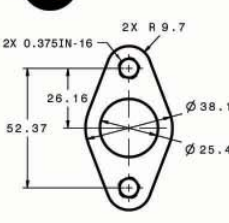

10

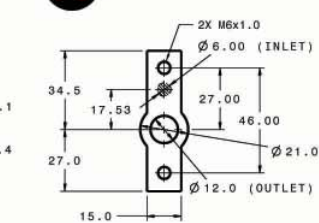

11

0.4375IN-24
 THREAD FOR Ø6.35 TUBE
 INVERTED FLARE CONNECTION
 PER SAE J512 (OIL INLET)

12

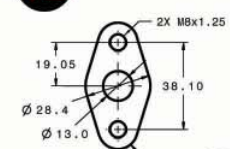

13

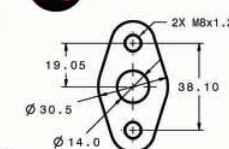

14

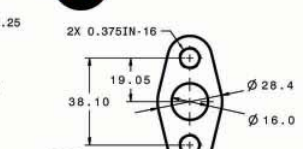

15

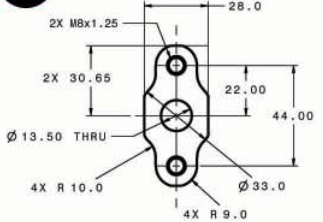

16

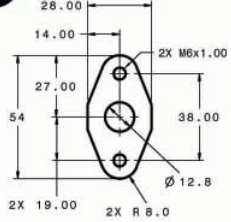

17

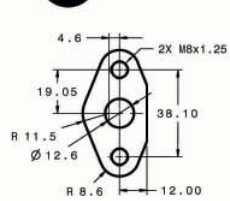

18

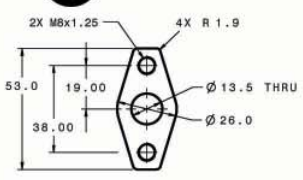

All Dimension Measurements in Millimeters (mm)

Sizes & Dimensions

Turbine Housing Outlet Flanges Sizes & Dimensions

Garrett®

01

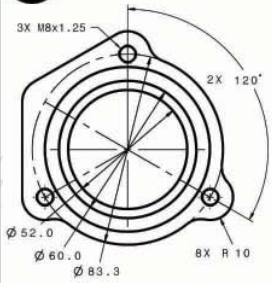

02

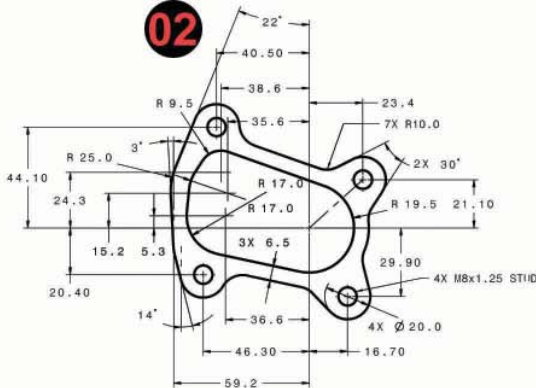

03

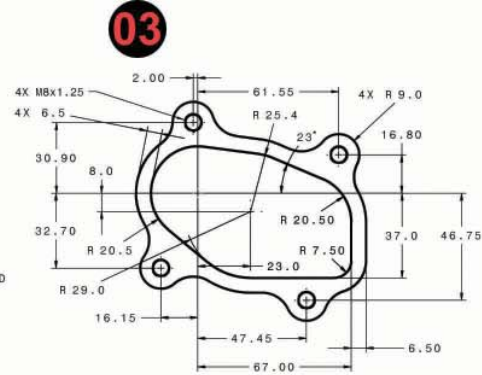

04

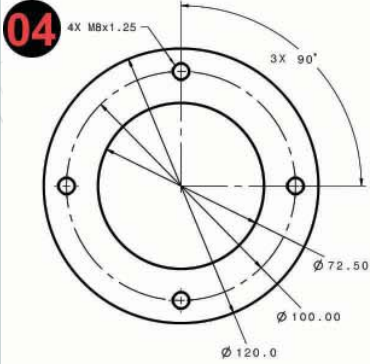

05

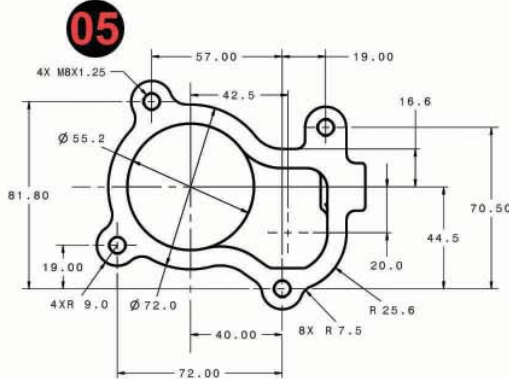

06

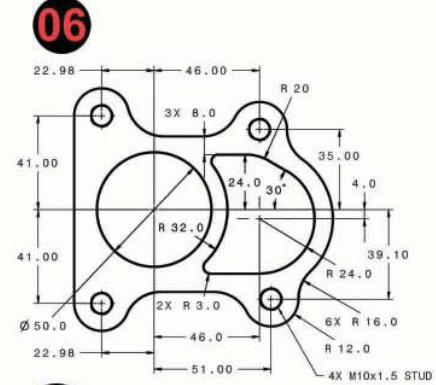

07 "3-INCH 4 BOLT"

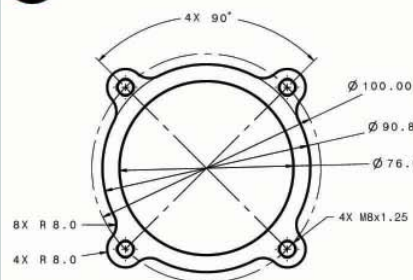

08

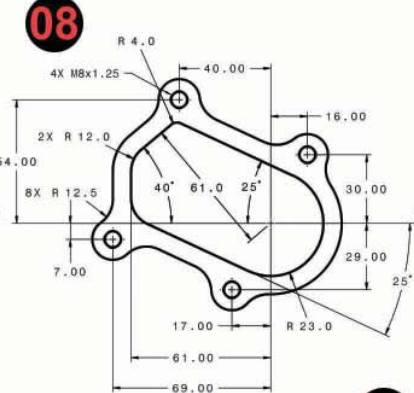

09 "5 BOLT"

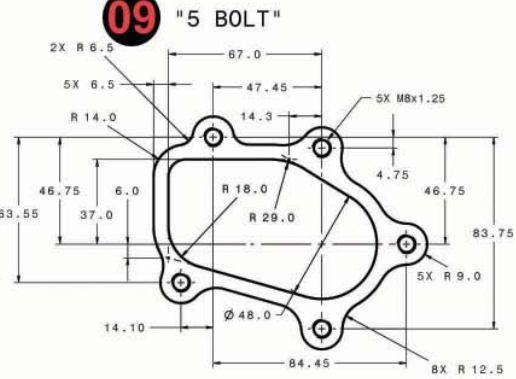

10 "5 BOLT"

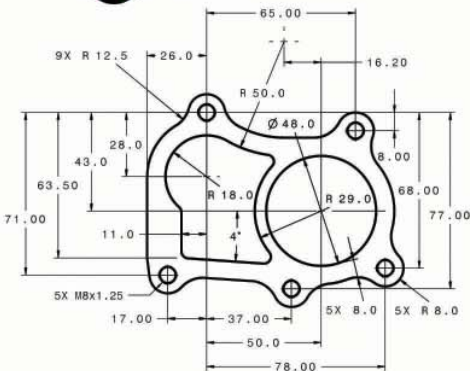

11 "5 BOLT"

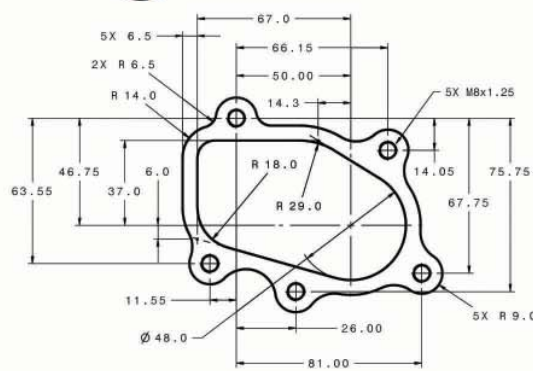

All Dimension Measurements in Millimeters (mm)

pursuit of power

Ø 7.476-7.485

Turbochargers > Sizes & Dimensions

Sizes & Dimensions

Turbine Housing Outlet Flanges & Water Lines
Sizes & Dimensions

01

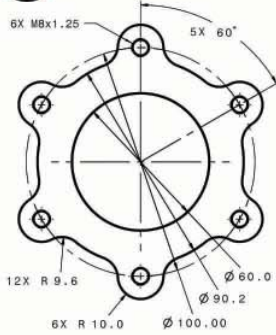

02

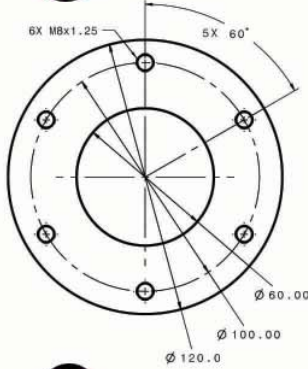

03

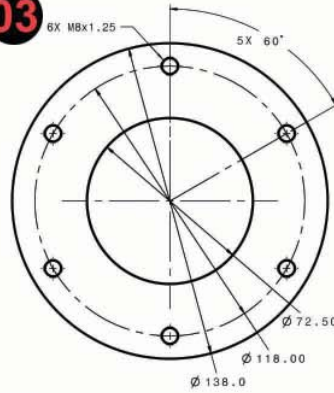

04

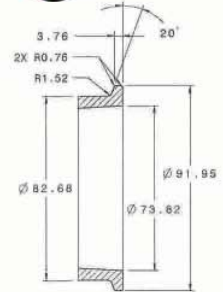

05

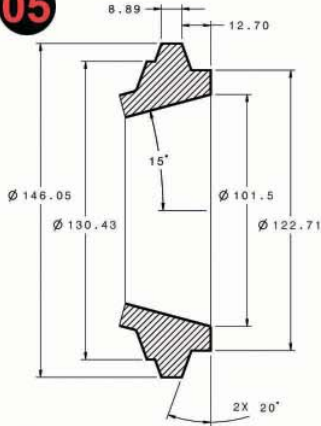

06

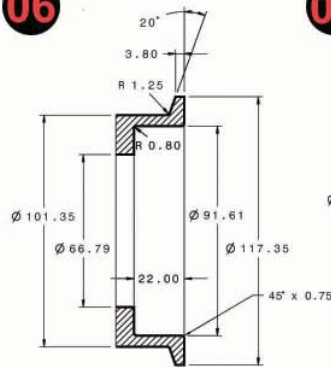

07

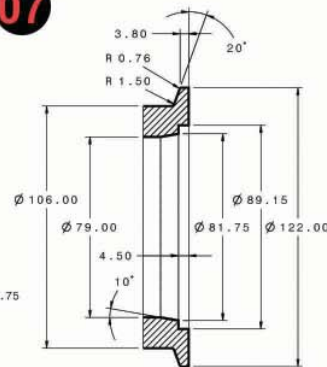

08

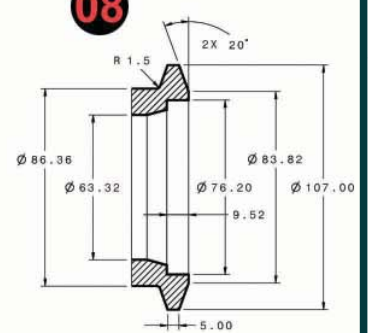

09

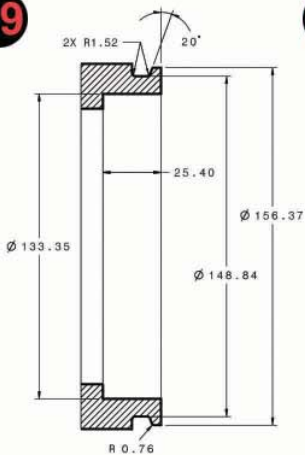

10

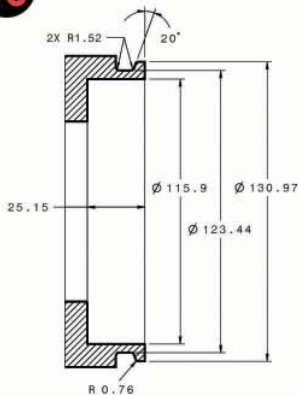

Water Connections

11	M12 x 1.50
12	M14 x 1.50
13	M18 x 1.50

All Dimension Measurements in Millimeters (mm)

High-Performance Stainless Steel Wastegate Assemblies

All wastegate assemblies are constructed with stainless steel valves and valve bodies. Actuator housings are CNC machined billet aluminum, with an optimal actuator to valve ratio or 2.2:1 for maximum flow capacity. The units are also designed with high temperature Nomex diaphragms and oxidation resistant Super Alloy components.



Note: Flanges sold separately

50mm Compressor Blow-Off Valve Assemblies

The TiAL Blow-Off Valve design is the result of extensive development and testing. The 50mm compressor bypass valve is a vital component of any turbocharged blow-through induction system. This custom TiAL manufactured Blow-Off Valve will improve throttle (time to boost) response as well as help relieve the damaging effects of compressor "surge loading". The CNC machined housings are available in several high luster anodized colors.



Note: Blow-Off Valve assemblies include fitting and V-band clamp. Flanges sold separately

TiAL Stainless Steel CNC Wastegate Flanges

Model	Part Number	Type	Configuration
38mm	716463-0001	Outlet	2 x thru hole
	716463-0002	Inlet	2 x M8-1.25
41mm	716464-0001	Outlet	4 x M6 x 1.0
	716466-0001	Inlet	4 x M6 x 1.0
46mm	716465-0001	Either	4 x thru hole

TiAL Blow-Off Valve Flanges

Part Number	Material
722783-0001	Aluminum (6061)
722783-0002	Steel (1018)
722783-0003	Stainless Steel (304L)

TiAL Wastegates

Valve Size (diameter)	Part Number	Spring Rate (bar / psi)
38mm	721490-2	0.3 / 3.6
	721490-3	0.4 / 5.8
	721490-4	0.6 / 8.7
41mm	721491-4	0.6 / 8.7
	721491-5	0.7 / 10.2
	721491-6	0.8 / 11.6
44mm	773115-1	0.7 / 10.2
	773115-2	0.8 / 12.6
	773115-3	0.9 / 13.1
46mm	721492-5	0.6 / 8.7
	721492-6	0.7 / 10.2
	721492-7	0.8 / 11.6

TiAL Blow-Off Valves

Part Number	Color
714341-0001	Red
714341-0002	Blue
714341-0003	Black
714341-0004	Violet
714341-0005	Machined Aluminum

pursuit of power

Garrett Intercooler Cores

Intercoolers

Air-Air, Bar-Plate or Tube-Fin
Air-Water

Intercooler Specifications

Intercooler Core Part Number	Design Type	Hot Flow Length (in.)	No Flow Height (in.)	Cold Flow Width (in.)	Core Weight (lbs.)	Supported Horsepower *
703521-6001	Bar-Plate	6.0	12.4	4.5	9.0	180
703519-6001	Bar-Plate	6.0	12.3	3.5	7.3	200
703517-6001	Bar-Plate	6.0	12.3	3.0	6.2	210
713447-6001	Tube-Fin	17.4	5.4	3.1	5.0	227
703521-6002	Bar-Plate	8.0	12.4	4.5	11.2	235
703519-6002	Bar-Plate	8.0	12.4	3.5	8.8	275
703517-6002	Bar-Plate	8.0	12.4	3.0	8.1	285
753447-6002	Bar-Plate	22.0	5.5	2.3	6.8	290
703518-6015	Bar-Plate	18.0	6.4	3.0	7.3	310
753447-6001	Bar-Plate	22.0	6.3	2.3	7.6	320
703520-6012	Bar-Plate	18.0	6.4	3.5	8.9	340
703517-6003	Bar-Plate	10.0	12.3	3.0	9.5	370
703519-6003	Bar-Plate	10.0	12.3	3.5	10.4	375
703521-6003	Bar-Plate	10.0	12.3	4.5	13.1	375
753447-6003	Bar-Plate	22.0	8.0	2.3	9.3	400
703520-6003	Bar-Plate	16.0	12.0	3.5	15.3	400
703520-6025	Bar-Plate	18.0	8.0	3.5	10.8	425
751341-6001	Bar-Plate	13.0	17.4	3.0	20.0	475
703518-6018	Bar-Plate	24.0	6.4	3.0	9.9	475
703518-6001	Bar-Plate	12.0	12.0	3.0	10.5	475
703520-6001	Bar-Plate	12.0	12.1	3.5	11.8	475
703522-6001	Bar-Plate	12.0	12.1	4.5	14.1	480
703520-6009	Bar-Plate	24.0	6.4	3.5	11.6	500
717874-6009	Air-Water	9.8	3.8	3.8	5.8	500
703518-6017	Bar-Plate	18.0	10.3	3.0	11.2	510
713372-6001	Tube-Fin	17.4	10.3	3.1	8.8	525
753447-6004	Bar-Plate	22.0	10.5	2.3	11.8	530
703520-6002	Bar-Plate	14.0	12.1	3.5	13.4	550
703520-6026	Bar-Plate	18.0	10.5	3.5	13.7	575
487085-6002	Bar-Plate	20.0	11.2	3.0	15.2	600
753447-6005	Bar-Plate	22.0	12.0	2.3	13.5	600
703520-6010	Bar-Plate	24.0	8.0	3.5	13.8	600
703518-6003	Bar-Plate	16.0	12.0	3.0	13.9	650
703520-6004	Bar-Plate	18.0	12.1	3.5	16.4	850
703522-6003	Bar-Plate	16.0	12.1	4.5	18.2	650
753447-6006	Bar-Plate	22.0	14.6	2.3	16.1	750
703518-6004	Bar-Plate	18.0	12.1	3.0	15.6	750
703522-6008	Bar-Plate	18.0	11.2	4.5	17.0	750
717874-6008	Air-Water	11.7	3.8	3.8	6.3	750
703518-6020	Bar-Plate	24.0	10.5	3.0	15.2	775
703522-6004	Bar-Plate	18.0	12.1	4.5	19.8	785
703520-6011	Bar-Plate	24.0	10.5	3.5	17.8	800
703518-6005	Bar-Plate	24.0	12.1	3.0	19.4	900
703520-6005	Bar-Plate	24.0	12.1	3.5	20.3	925
703522-6005	Bar-Plate	24.0	12.1	4.5	26.2	950
485257-6001	Tube-Fin	25.4	15.5	2.6	13.0	975
486827-6002	Bar-Plate	23.7	12.0	3.8	23.7	1000
734408-6005	Air-Water	11.9	4.8	4.8	8.6	1000
701596-6001	Bar-Plate	27.8	12.7	5.1	31.4	1260

* Horsepower rating shown for nominal operating conditions. Maximum horsepower potential may be higher than the listed values.

All Turbos

Comparison of
The Entire Garrett® GT Line



TURBO							COMPRESSOR				TURBINE				APPLICATION		
Pg.	Turbo	PN	CHRA PN	Bearing	Cooling		Ind Whl Dia	Exd Whl Dia	Trim	A/R	Whl Dia	Trim	A/R	Type	HP	Engine	
18	TR3069R	See a Garrett® Distributor		Ball	Oil		43.8mm	69.3mm	40	0.50	60.0mm	73	0.57	Free Float	200 - 320	1.6L - 2.5L	
18	TR3069R	See a Garrett® Distributor		Ball	Oil		43.8mm	69.3mm	40	0.50	60.0mm	76	0.57	Free Float	200 - 320	1.6L - 2.5L	
18	TR3069R	See a Garrett® Distributor		Ball	Oil		51.9mm	69.3mm	56	0.70	60.0mm	73	0.57	Free Float	280 - 460	1.8L - 3.0L	
18	TR3069R	See a Garrett® Distributor		Ball	Oil		51.9mm	69.3mm	56	0.70	60.0mm	76	0.57	Free Float	280 - 460	1.8L - 3.0L	
18	TR3076R	See a Garrett® Distributor		Ball	Oil		48.2mm	76.2mm	40	0.50	60.0mm	73	0.57	Free Float	230 - 410	1.6L - 2.5L	
18	TR3076R	See a Garrett® Distributor		Ball	Oil		48.2mm	76.2mm	40	0.50	60.0mm	76	0.57	Free Float	230 - 410	1.6L - 2.5L	
18	TR3076R	See a Garrett® Distributor		Ball	Oil		57.0mm	76.2mm	56	0.70	60.0mm	73	0.57	Free Float	325 - 560	1.8L - 3.0L	
18	TR3076R	See a Garrett® Distributor		Ball	Oil		57.0mm	76.2mm	56	0.70	60.0mm	76	0.57	Free Float	325 - 560	1.8L - 3.0L	
18	TR30R					Turbine Housing Option								0.67	Free Float		
18	TR30R					Turbine Housing Option								0.80	Free Float		
19	GT1241	756068-1	757864-1	Journal	Oil & Water		29.0mm	41.0mm	50	0.33	35.5mm	72	0.43	Wastegated	50 - 130	0.4L - 1.2L	
-	GT1544	454082-2	433289-116	Journal	Oil		32.9mm	43.9mm	56	0.33	42.2mm	58	0.34	Wastegated	100 - 150	1.0L - 1.6L	
-	GT1544	454083-2	433289-50	Journal	Oil		32.9mm	43.9mm	56	0.33	42.2mm	58	0.35	Wastegated	100 - 150	1.0L - 1.6L	
20	GT1548	466755-3	431876-93	Journal	Oil & Water		37.2mm	48.0mm	60	0.48	41.2mm	72	0.35	Wastegated	100 - 200	1.0L - 1.6L	
-	GT2052	727264-1	451298-43	Journal	Oil		37.6mm	52.2mm	52	0.51	47.0mm	72	0.50	Wastegated	140 - 225	1.4L - 2.0L	
-	GT2052	727264-2	451298-43	Journal	Oil		37.6mm	52.2mm	52	0.51	47.0mm	72	0.50	Wastegated	140 - 225	1.4L - 2.0L	
-	GT2052	727264-4	451298-45	Journal	Oil		36.8mm	52.2mm	50	0.51	47.0mm	72	0.50	Wastegated	140 - 225	1.4L - 2.0L	
-	GT2052	727264-5	451298-45	Journal	Oil		36.8mm	52.2mm	50	0.51	47.0mm	72	0.50	Wastegated	140 - 225	1.4L - 2.0L	
-	GT2052	727264-3	451298-44	Journal	Oil		36.1mm	52.2mm	48	0.51	47.0mm	72	0.50	Wastegated	140 - 225	1.4L - 2.0L	
-	GT2052	727264-7	451298-44	Journal	Oil		36.1mm	52.2mm	48	0.51	47.0mm	72	0.50	Wastegated	140 - 225	1.4L - 2.0L	
21	GT2056	751578-2	433298-234	Journal	Oil		41.5mm	56.0mm	55	0.53	47.0mm	72	0.46	Wastegated	140 - 260	1.4L - 2.0L	
22	GT2252	452187-6	451298-6	Journal	Oil		40.2mm	52.0mm	60	0.51	50.3mm	72	0.67	Wastegated	150 - 260	1.7L - 2.5L	
22	GT2252					Turbine Housing Option (PN 451503-1)								0.56	Free Float		
-	GT2259	452214-3	451298-9	Journal	Oil		42.8mm	59.4mm	52	0.42	50.3mm	72	0.56	Free Float	160 - 280	1.7L - 2.5L	
-	GT2259					Turbine Housing Option (PN 436313-6)								0.67	Wastegated		
-	GT2554R	471171-3	446179-24	Ball	Oil & Water		42.0mm	54.3mm	60	0.80	53.0mm	62	0.64	Wastegated	170 - 270	1.4L - 2.2L	
23	GT2560R	466541-1	446179-12	Ball	Oil & Water		46.5mm	60.0mm	60	0.60	53.0mm	62	0.64	Wastegated	200 - 330	1.6L - 2.5L	
23	GT2560R	466541-4	446179-38	Ball	Oil & Water		46.5mm	60.0mm	60	0.60	53.0mm	62	0.64	Wastegated	200 - 330	1.6L - 2.5L	
-	GT2854R	471171-9	446179-47	Ball	Oil & Water		42.0mm	54.3mm	60	0.80	53.8mm	62	0.64	Wastegated	170 - 270	1.4L - 2.2L	
24	GT2860R	707160-5	446179-51	Ball	Oil & Water		47.2mm	60.0mm	62	0.60	53.8mm	76	0.64	Wastegated	250 - 360	1.8L - 3.0L	
24	GT2860R					Turbine Housing Option (PN 430609-230)								0.64	Wastegated		
-	GT2860R	707160-7	446179-54	Ball	Oil & Water		44.5mm	60.0mm	55	0.42	53.8mm	62	0.64	Wastegated	150 - 310	1.8L - 3.0L	
25	GT2860RS	739548-1	446179-66	Ball	Oil & Water		47.2mm	60.0mm	62	0.60	53.8mm	76	0.86	Wastegated	250 - 360	1.8L - 3.0L	
25	GT2860RS	739548-5	446179-66	Ball	Oil & Water		47.2mm	60.0mm	62	0.60	53.8mm	76	0.64	Wastegated	250 - 360	1.8L - 3.0L	
25	GT2860RS					Turbine Housing Option (PN 430609-230)								0.64	Wastegated		
25	GT2860RS					Turbine Housing Option (PN 430609-231)								0.86	Wastegated		
-	GT2871R	472560-15	446179-67	Ball	Oil & Water		51.2mm	71.0mm	52	0.60	53.8mm	76	0.64	Wastegated	280 - 460	1.8L - 3.0L	
-	GT2871R					Turbine Housing Option (PN 430609-231)								0.86	Wastegated		
-	GT2871R	743347-1	446179-31	Ball	Oil & Water		49.2mm	71.0mm	48	0.60	53.8mm	76	0.86	Wastegated	250 - 400	1.8L - 3.0L	
-	GT2871R					Turbine Housing Option (PN 430609-230)								0.64	Wastegated		
26	GT2871R	743347-2	446179-32	Ball	Oil & Water		53.1mm	71.0mm	56	0.60	53.8mm	76	0.86	Wastegated	280 - 475	1.8L - 3.0L	
26	GT2871R					Turbine Housing Option (PN 430609-230)								0.64	Wastegated		
26	GT2871R					Compressor Housing Kit Option (PN 756021-1)	2.75" Hose	2.00" Hose		0.50							
26	GT2871R					Compressor Housing Kit Option (PN 756021-2)	4.00" Hose	2.00" Hose		0.50							
27	GT2876R	705330-1	446179-18	Ball	Oil & Water		52.7mm	76.0mm	48	0.70	53.8mm	76	0.64	Wastegated	280 - 480	1.8L - 3.0L	
27	GT2876R	705330-2	446179-18	Ball	Oil & Water		52.7mm	76.0mm	48	0.70	53.8mm	76	0.86	Wastegated	280 - 480	1.8L - 3.0L	
27	GT2876R					Turbine Housing Option (PN 430609-230)								0.64	Wastegated		
27	GT2876R					Turbine Housing Option (PN 430609-231)								0.86	Wastegated		
-	GT3071R		700177-23	Ball	Oil & Water		53.1mm	71.0mm	56	-	60.0mm	84				300 - 460	1.8L - 3.0L
-	GT3071R					Turbine Housing Option (PN 740902-1)								1.06	Free Float		
-	GT3071R					Turbine Housing Option (PN 740902-2)								0.82	Free Float		
-	GT3071R					Turbine Housing Option (PN 740902-3)								0.63	Free Float		
-	GT3071R					Compressor Housing Option (PN 756021-1)	2.75" Hose	2.00" Hose		0.50							
-	GT3071R					Compressor Housing Option (PN 756021-2)	4.00" Hose	2.00" Hose		0.50							
28	GT3071R	700382-3	700177-3	Ball	Oil & Water		53.1mm	71.0mm	56	0.50	56.5mm	84	0.64	Wastegated	310 - 475	1.8L - 3.0L	
28	GT3071R	700382-20	700177-4	Ball	Oil & Water		53.1mm	71.0mm	56	0.50	56.5mm	90	0.86	Wastegated	310 - 475	1.8L - 3.0L	
28	GT3071R					Compressor Housing Kit Option (PN 756021-1)	2.75" Hose	2.00" Hose		0.50							
28	GT3071R					Compressor Housing Kit Option (PN 756021-2)	4.00" Hose	2.00" Hose		0.50							
29	GT3076R	700382-12	700177-7	Ball	Oil & Water		57.0mm	76.2mm	56	0.60	60.0mm	84				310 - 525	2.0L - 3.5L
29	GT3076R					Turbine Housing Option (PN 740902-1)								1.06	Free Float		
29	GT3076R					Turbine Housing Option (PN 740902-2)								0.82	Free Float		
29	GT3076R					Turbine Housing Option (PN 740902-3)								0.63	Free Float		
-	GT3267	452233-5	436058-6	Journal	Oil		48.3mm	67.0mm	52	0.48	64.0mm	70	0.69	Wastegated	200 - 400	2.0L - 3.0L	
-	GT3267	452234-2	436058-4	Journal	Oil		46.4mm	67.0mm	48	0.48	64.0mm	73	0.78	Free Float	200 - 400	2.0L - 3.0L	
30	GT3271	452203-1	436058-3	Journal	Oil		51.2mm	71.0mm	52	0.50	64.0mm	73	0.78	Wastegated	200 - 420	2.0L - 3.0L	
30	GT3271					Turbine Housing Option (PN 451225-26)								0.78	Free Float		
30	GT3271					Turbine Housing Option (PN 435066-32)								0.69	Wastegated		
-	GT3571	731413-1	436058-11	Journal	Oil		51.2mm	71.0mm	52	0.50	68.0mm	84	1.18	Free Float	250 - 390	2.5L - 3.5L	
-	GT3571					Turbine Housing Option (PN 714690-13)								1.05	Free Float		
-	GT3571					Compressor Wheel & Housing Kit (PN 731428-1)	54.8mm	76.0mm	52	0.50							
31	GT3582R	714568-1	706451-5	Ball	Oil & Water		61.4mm	82.0mm	56	0.70	68.0mm	84	1.06	Free Float	400 - 600	2.0L - 4.5L	
31	GT3582R	714568-2	706451-5	Ball	Oil & Water		61.4mm	82.0mm	56	0.70	68.0mm	84	0.82	Free Float	400 - 600	2.0L - 4.5L	
31	GT3582R	714568-3	706451-5	Ball	Oil & Water		61.4mm	82.0mm	56	0.70	68.0mm	84	0.63	Free Float	400 - 600	2.0L - 4.5L	
31	GT3582R					Turbine Housing Option (PN 740902-4)								1.06	Free Float		
31	GT3582R					Turbine Housing Option (PN 740902-5)								0.82	Free Float		
31	GT3582R					Turbine Housing Option (PN 740902-6)								0.63	Free Float		
-	GT3776	452159-1	436085-1	Journal	Oil		55.0mm	76.2mm	52	0.54	72.5mm	84	1.12	Free Float	320 - 500	2.0L - 4.0L	
-	GT3776					Compressor Wheel & Housing Kit (PN 731428-3)	59.1mm	82.0mm	52	0.54							
-	GT3782	452159-3	436085-5	Journal	Oil		59.1mm	82.0mm	52	0.54	72.5mm	84	1.12	Free Float	350 - 550	2.0L - 4.0L	
32	GT4082	452232-5	449739-10	Journal	Oil		58.0mm	82.0mm	50	0.58	77.0mm	73	0.94	Free Float	370 - 575	2.0L - 6.0L	
-	GT4088	703457-2	449739-34	Journal	Oil		64.7mm	88.0mm	54	0.72	77.0mm	84	1.34	Free Float	450 - 700	2.0L - 6.0L	
-	GT4088					Turbine Housing Option (PN 434309-88)								1.19	Free Float		
33	GT4088R	751470-1	751450-9	Ball	Oil & Water		63.5mm	88.0mm	52	0.72	77.0mm	78	0.85	Free Float	400 - 700	2.0L - 6.0L	
33	GT4088R	751470-2	751450-9	Ball	Oil & Water		63.5mm	88.0mm	52	0.72	77.0mm	78	0.95	Free Float	400 - 700	2.0L - 6.0L	
33	GT4088R	751470-3	751450-9	Ball	Oil & Water		63.5mm	88.0mm	52</								

pursuit of power

Turbo Comparisons > All Turbos

All Turbos

Comparison of
The Entire Garrett® GT Line

TURBO					COMPRESSOR				TURBINE				APPLICATION		
Pg.	Turbo	PN	CHRA PN	Bearing	Cooling	Ind Whl Dia	Exd Whl Dia	Trim	A/R	Whl Dia	Trim	A/R	Type	HP	Engine
33	GT4088R	Turbine Housing Option (PN 448375-18)										0.85	Free Float		
33	GT4088R	Turbine Housing Option (PN 448375-19)										0.95	Free Float		
33	GT4088R	Turbine Housing Option (PN 448375-20)										1.06	Free Float		
34	GT4094R	751470-19	751450-16	Ball	Oil & Water	67.8mm	94.0mm	52	0.72	77.0mm	78	0.85	Free Float	450 - 800	2.0L - 5.7L
34	GT4094R	751470-20	751450-16	Ball	Oil & Water	67.8mm	94.0mm	52	0.72	77.0mm	78	0.95	Free Float	450 - 800	2.0L - 5.7L
34	GT4094R	751470-21	751450-16	Ball	Oil & Water	67.8mm	94.0mm	52	0.72	77.0mm	78	1.06	Free Float	450 - 800	2.0L - 5.7L
34	GT4094R	751470-22	751450-16	Ball	Oil & Water	67.8mm	94.0mm	52	0.72	77.0mm	78	1.19	Free Float	450 - 800	2.0L - 5.7L
34	GT4094R	Turbine Housing Option (PN 448375-18)										0.85	Free Float		
34	GT4094R	Turbine Housing Option (PN 448375-19)										0.95	Free Float		
34	GT4094R	Turbine Housing Option (PN 448375-20)										1.06	Free Float		
34	GT4094R	Turbine Housing Option (PN 448375-21)										1.19	Free Float		
-	GT4294	731376-1	712402-7	Journal	Oil	70.3mm	94.0mm	56	0.60	82.0mm	84	1.15	Free Float	500 - 850	2.0L - 8.0L
35	GT4294R	774595-1	451888-9	Ball	Oil & Water	70.3mm	94.0mm	56	0.60	82.0mm	84	1.01	Free Float	500 - 850	2.0L - 8.0L
35	GT4294R	774595-2	451888-9	Ball	Oil & Water	70.3mm	94.0mm	56	0.60	82.0mm	84	1.15	Free Float	500 - 850	2.0L - 8.0L
35	GT4294R	774595-3	451888-9	Ball	Oil & Water	70.3mm	94.0mm	56	0.60	82.0mm	84	1.28	Free Float	500 - 850	2.0L - 8.0L
35	GT4294R	774595-4	451888-9	Ball	Oil & Water	70.3mm	94.0mm	56	0.60	82.0mm	84	1.44	Free Float	500 - 850	2.0L - 8.0L
35	GT4294(R)	Turbine Housing Option (PN 757707-1)										1.01	Free Float		
35	GT4294(R)	Turbine Housing Option (PN 757707-2)										1.15	Free Float		
35	GT4294(R)	Turbine Housing Option (PN 757707-3)										1.28	Free Float		
35	GT4294(R)	Turbine Housing Option (PN 757707-4)										1.44	Free Float		
35	GT4294(R)	Turbine Housing Option (PN 757707-10)										1.01	Free Float		
35	GT4294(R)	Turbine Housing Option (PN 757707-9)										1.15	Free Float		
35	GT4294R	Compressor Housing Kit (PN 757708-1)				5.00"Hose	4.00"V-Band	56	0.60						
-	GT4202	731376-2	712402-8	Journal	Oil	74.7mm	102.3mm	53	0.60	82.0mm	84	1.15	Free Float	500 - 1000	2.0L - 8.0L
36	GT4202R	774595-5	451888-11	Ball	Oil & Water	74.7mm	102.3mm	53	0.60	82.0mm	84	1.01	Free Float	700 - 1000	2.0L - 8.0L
36	GT4202R	774595-6	451888-11	Ball	Oil & Water	74.7mm	102.3mm	53	0.60	82.0mm	84	1.15	Free Float	700 - 1000	2.0L - 8.0L
36	GT4202R	774595-7	451888-11	Ball	Oil & Water	74.7mm	102.3mm	53	0.60	82.0mm	84	1.28	Free Float	700 - 1000	2.0L - 8.0L
36	GT4202R	774595-8	451888-11	Ball	Oil & Water	74.7mm	102.3mm	53	0.60	82.0mm	84	1.44	Free Float	700 - 1000	2.0L - 8.0L
36	GT4202(R)	Turbine Housing Option (PN 757707-1)										1.01	Free Float		
36	GT4202(R)	Turbine Housing Option (PN 757707-2)										1.15	Free Float		
36	GT4202(R)	Turbine Housing Option (PN 757707-3)										1.28	Free Float		
36	GT4202(R)	Turbine Housing Option (PN 757707-4)										1.44	Free Float		
36	GT4202(R)	Turbine Housing Option (PN 757707-10)										1.01	Free Float		
36	GT4202(R)	Turbine Housing Option (PN 757707-9)										1.15	Free Float		
36	GT4202R	Compressor Housing Kit (PN 757708-2)				5.00"Hose	4.21"V-Band	53	0.60						
37	GT4508R	774596-1	451888-28	Ball	Oil & Water	80.8mm	108.0mm	56	0.69	87.0mm	85	1.01	Free Float	700 - 1100	2.0L - 8.0L
37	GT4508R	774596-2	451888-28	Ball	Oil & Water	80.8mm	108.0mm	56	0.69	87.0mm	85	1.15	Free Float	700 - 1100	2.0L - 8.0L
37	GT4508R	774596-3	451888-28	Ball	Oil & Water	80.8mm	108.0mm	56	0.69	87.0mm	85	1.28	Free Float	700 - 1100	2.0L - 8.0L
37	GT4508R	774596-4	451888-28	Ball	Oil & Water	80.8mm	108.0mm	56	0.69	87.0mm	85	1.44	Free Float	700 - 1100	2.0L - 8.0L
37	GT4508R	Turbine Housing Option (PN 757707-5)										1.01	Free Float		
37	GT4508R	Turbine Housing Option (PN 757707-6)										1.15	Free Float		
37	GT4508R	Turbine Housing Option (PN 757707-7)										1.28	Free Float		
37	GT4508R	Turbine Housing Option (PN 757707-8)										1.44	Free Float		
-	GT4708	767564-1	767546-1	Journal	Oil	80.7mm	108.0mm	56	0.69	92.7mm	82	-	-	700 - 1200	2.5L - 10.0L
38	GT4708R	769112-1	769210-1	Ball	Oil	80.7mm	108.0mm	56	0.69	92.7mm	82	0.96	Free Float	700 - 1200	2.5L - 10.0L
38	GT4708R	769112-2	769210-1	Ball	Oil	80.7mm	108.0mm	56	0.69	92.7mm	82	1.08	Free Float	700 - 1200	2.5L - 10.0L
38	GT4708R	769112-3	769210-1	Ball	Oil	80.7mm	108.0mm	56	0.69	92.7mm	82	1.23	Free Float	700 - 1200	2.5L - 10.0L
38	GT4708R	769112-4	769210-1	Ball	Oil	80.7mm	108.0mm	56	0.69	92.7mm	82	1.39	Free Float	700 - 1200	2.5L - 10.0L
-	GT4718	763740-2	767564-2	Journal	Oil	88.0mm	117.6mm	56	0.69	92.7mm	82	-	-	850 - 1400	2.5L - 10.0L
39	GT4718R	769112-5	769210-2	Ball	Oil	88.0mm	117.6mm	56	0.69	92.7mm	82	0.96	Free Float	850 - 1400	2.5L - 10.0L
39	GT4718R	769112-6	769210-2	Ball	Oil	88.0mm	117.6mm	56	0.69	92.7mm	82	1.08	Free Float	850 - 1400	2.5L - 10.0L
39	GT4718R	769112-7	769210-2	Ball	Oil	88.0mm	117.6mm	56	0.69	92.7mm	82	1.23	Free Float	850 - 1400	2.5L - 10.0L
39	GT4718R	769112-8	769210-2	Ball	Oil	88.0mm	117.6mm	56	0.69	92.7mm	82	1.39	Free Float	850 - 1400	2.5L - 10.0L
39	GT4708&18(R)	Turbine Housing Option (PN 761208-9)										0.96	Free Float		
39	GT4708&18(R)	Turbine Housing Option (PN 761208-10)										1.08	Free Float		
39	GT4708&18(R)	Turbine Housing Option (PN 761208-11)										1.23	Free Float		
39	GT4708&18(R)	Turbine Housing Option (PN 761208-12)										1.39	Free Float		
-	GT5533	752052-9	449530-49	Journal	Oil	91.2mm	133.0mm	47	-	111.5mm	84	-	-	1000 - 1550	3.0L - 12.0L
40	GT5533R	775844-1	769210-3	Ball	Oil	91.2mm	133.0mm	47	0.69	111.4mm	84	-	-	1000 - 1550	3.0L - 12.0L
40	GT5533(R)	Turbine Housing Option (PN 761208-13)										0.90	Free Float		
40	GT5533(R)	Turbine Housing Option (PN 761208-14)										1.00	Free Float		
40	GT5533(R)	Turbine Housing Option (PN 761208-15)										1.12	Free Float		
40	GT5533(R)	Turbine Housing Option (PN 761208-16)										1.24	Free Float		
40	GT5533(R)	Turbine Housing Option (PN 761208-17)										1.40	Free Float		
41	GT6041	731377-1	730496-1	Journal	Oil	105.7mm	141.0mm	56	1.05	130.0mm	84	1.47	Free Float	1450 - 2000	6.0L - 12.0L
41	GT6041	Turbine Housing Option (PN 441319-97)										1.25	Free Float		
42	T04B	-	757197-1	Ball	Oil & Water	59.0mm	76.0mm	60	-	74.2mm	76	-	-		
42	T04Z	-	740759-2	Ball	Oil & Water	66.7mm	84.0mm	63	-	74.2mm	76	-	-		
42	T3/T4R	-	757197-2	Ball	Oil & Water	56.6mm	75.0mm	57	-	65.0mm	76	-	-		
42	T3/T4R	-	757197-3	Ball	Oil & Water	58.0mm	75.0mm	60	-	65.0mm	76	-	-		
42	T3/T4R	-	757197-4	Ball	Oil & Water	53.9mm	76.0mm	50	-	65.0mm	76	-	-		
42	T3/T4R	-	757197-5	Ball	Oil & Water	59.0mm	76.0mm	60	-	65.0mm	76	-	-		
42	T350R	-	757197-7	Ball	Oil & Water	59.0mm	76.0mm	60	-	71.0mm	76	-	-		

If no page number is listed, please see www.TurboByGarrett.com for turbocharger details

9. FOR ADDITIONAL INSTALLATION RECOMMENDATIONS

TURBOCHARGER AXIS OF ROTATION SHOULD BE NORMAL TO DIRECTION OF GRAVITY WITHIN 45° WHEN INSTALLED IN VEHICLE ON LEVEL GROUND.

5. TURBOCHARGER TO BE MOUNTED FROM TURBINE HOUSING

2. DIMENSIONS ARE IN MILLIMETERS.

OIL OUTLET SHOULD BE IN DIRECTION OF GRAVITY WITHIN 45° WHEN INSTALLED IN VEHICLE ON LEVEL GROUND. OIL MUST BE DRAINED REGULARLY BY GRAVITY

1. ALL UNTOLERANCED DIMENSIONS ARE FOR REFERENCE PURPOSES ONLY

MINIMUM ID OF OIL DRAIN TUBE IS 19.0.

UNLESS OTHERWISE SPECIFIED

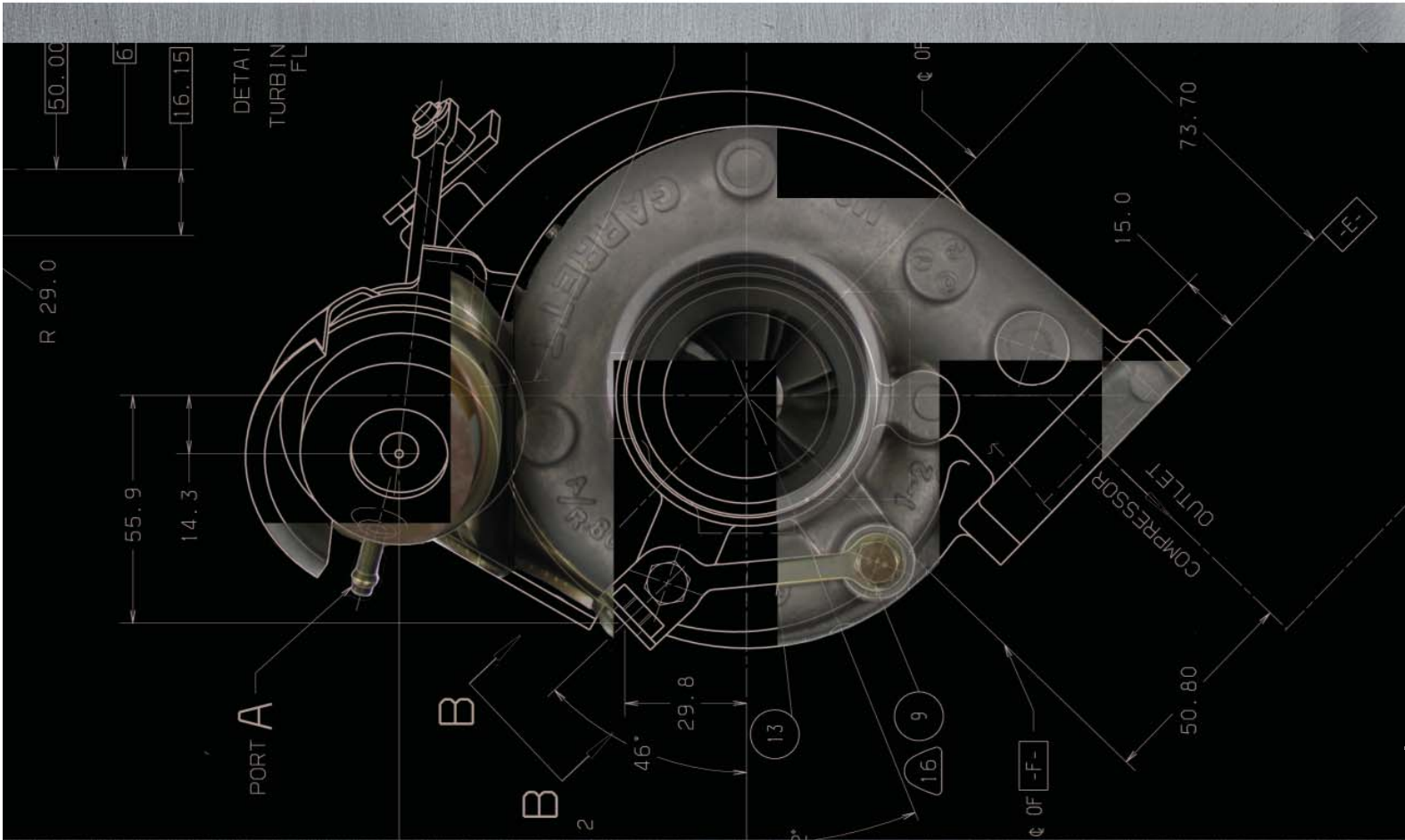

www.TurboByGarrett.com

Honeywell Turbo Technologies
 3201 W. Lomita Blvd.
 Torrance, CA 90505

Honeywell